

# Owner's Manual

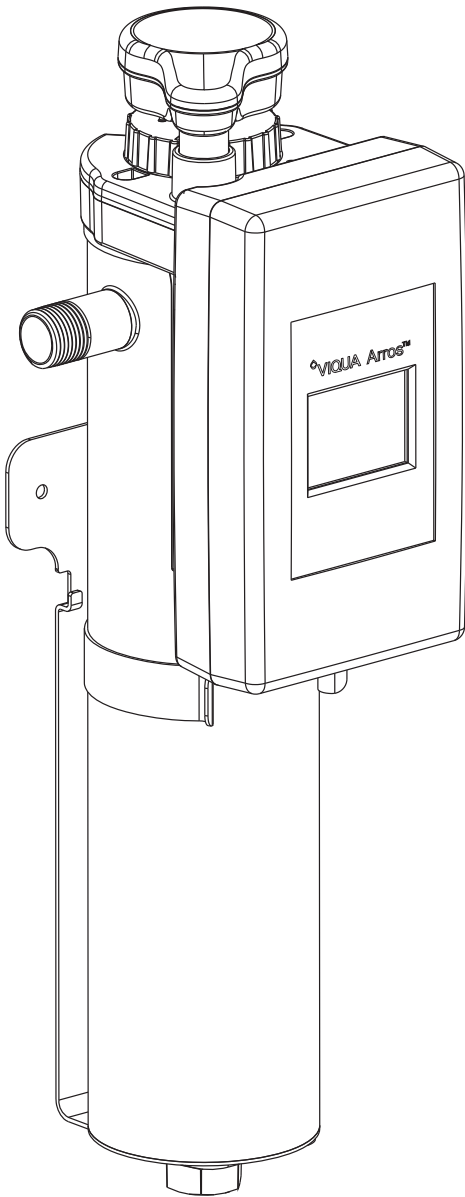

**VIQUA Arros® Models:**  
Arros 9, Arros 15, Arros 22

**NSF Standard 55 Class B  
Validated Models:**

**Arros 9-V, Arros 15-V, Arros 22-V**



Arros 9-V, Arros 15-V, Arros 22-V  
Tested and Certified by  
NSF International against CSA  
B483.1 and NSF/ANSI 55 for  
Disinfection Performance, Class B



---

## Congratulations

on the purchase of your ultraviolet (UV) water system! This system uses the most advanced UV technology on the market and is designed to provide you with years of trouble free operation with minimal maintenance.

To ensure ongoing optimal operation, UV lamps need to be replaced annually with VIQUA factory-supplied replacements. VIQUA lamps are the result of extensive development resulting in a highly efficient platform with extremely stable UV output over the entire 9000 hour lifetime. Its success has led to a proliferation of non-genuine copies in the market.

The UV lamp is the heart of the UV System, and there should be no compromise when it's time for a replacement.

Why should you insist on genuine factory supplied VIQUA replacement lamps?

- Use of widely available, non-genuine, replacement lamps has been shown to damage the control module of VIQUA UV equipment.
- An increasing number of calls to VIQUA Technical Support are connected with non-genuine lamps being used (unknowingly) as replacements.
- Damage arising from the use of non-genuine lamps poses a safety risk and is not covered by equipment warranty.
- Unless the UV equipment is equipped with a UV sensor (monitor), it is not possible to verify the UV (invisible) output of replacement lamps.
- Similar appearance to the original lamp and the presence of (visible) blue light does not mean equivalent performance.
- VIQUA replacement lamps undergo rigorous performance testing and strict quality control processes to ensure that the safety and performance certifications of the original equipment are not compromised.

So, you can see that it's simply not worth the risk! Insist on genuine VIQUA replacement lamps.

















# Section 1 Safety Information

These are the original instructions. Please read this entire manual before operating this equipment. Pay attention to all danger, warning, and caution statements in this manual. Failure to do so could result in serious personal injury or damage to the equipment.

Make sure that the protection provided by this equipment is not impaired. DO NOT use or install this equipment in any manner other than that specified in the installation manual.



## 1.1 Potential Hazards:

Read all labels and tags attached to the system. Personal injury or damage to the system could occur if not observed.



	Waste electrical and electronic equipment (WEEE). This symbol indicates that you should not discard wasted electrical or electronic equipment (WEEE) in the trash. For proper disposal, contact your local recycling/reuse or hazardous waste center.		This symbol indicates there is a potential for VERY hot water when flow is started.
	This symbol indicates there is Mercury present.		This symbol indicates not to store any combustible or flammable material close to the system.
	This is the safety alert symbol. Obey all safety messages that follow this symbol to avoid potential injury. When on the equipment, refer to the Operational and Maintenance manual for additional safety information.		This symbol indicates that the contents of the transport package are fragile and the package should be handled with care.
	This symbol indicates a risk of electrical shock and/or electrocution exists.		This symbol indicates safety glasses with side protection is required for protection against UV exposure.
	This symbol indicates the marked equipment may contain a component that can eject forcibly. Obey all procedures to safely depressurize.		This symbol indicates gloves must be worn.
	This symbol indicates the system is under pressure.		This symbol indicates safety boots must be worn.
	This symbol indicates the marked item could inject fluid into the skin.		This symbol indicates the operator must read all available documentation to perform required procedures.
	This symbol indicates there is a potential UV hazard. Proper protection must be worn.		This symbol indicates that the system should only be connected to a properly grounded, grounding-type controller receptacle that is protected by a Ground Fault Circuit Interrupter (GFCI).
	This symbol indicates the marked item could be hot and should not be touched without care.		

## 1.2 Safety Precautions:

### **⚠ DANGER**



 	<p>Failure to follow these instructions will result in serious injury or death.</p> <ul style="list-style-type: none"><li>• <b>Electric Shock:</b> To avoid possible electric shock, special care should be taken since water is present near the electrical equipment. Unless a situation is encountered that is explicitly addressed by the provided maintenance and troubleshooting sections, DO NOT attempt repairs yourself, refer to an authorized service facility.</li><li>• <b>GROUNDING:</b> This product must be grounded. If it should malfunction or breakdown, grounding provides a path of least resistance for electric current to reduce the risk of electrical shock. This system is equipped with a cord having an equipment-grounding conductor and a grounding plug. The plug must be plugged into an appropriate outlet that is properly installed and grounded in accordance with all local codes and ordinances. Improper connection of the equipment-grounding conductor can result in a risk of electrocution. Check with a qualified electrician or service personnel if you are in doubt as to whether the outlet is properly grounded. DO NOT modify the plug provided with this system – if it does not fit in the outlet, have a proper outlet installed by a qualified electrician. DO NOT use any type of adapter with this system.</li><li>• <b>GROUND FAULT CIRCUIT INTERRUPTER PROTECTION:</b> To comply with the National Electrical Code (NFPA 70) and to provide additional protection from the risk of electric shock, this system should only be connected to a properly grounded, grounding-type controller receptacle that is protected by a Ground Fault Circuit Interrupter (GFCI) or to a residual current device (RCD) having a rated residual operating current not exceeding 30 mA. Inspect operation of GFCI as per manufacturer's suggested maintenance schedule.</li><li>• DO NOT operate the UV System if it has a damaged cord or plug, if it is malfunctioning or if it has been dropped or damaged in any manner.</li><li>• DO NOT use this UV System for other than intended use (potable water applications). The use of attachments not recommended or sold by the manufacturer / distributor may cause an unsafe condition.</li><li>• DO NOT install this UV System where it will be exposed to the weather or to temperatures below freezing.</li><li>• DO NOT store this UV System where it will be exposed to the weather.</li><li>• DO NOT store this UV System where it will be exposed to temperatures below freezing unless all water has been drained from it and the water supply has been disconnected.</li></ul>
--	---

### **⚠ WARNING**

 	<ul style="list-style-type: none"><li>• During extended periods of no water flow, the water in your UV Chamber can become very hot (Approx. 60 °C) and potentially lead to scalding. It is recommended to run your water until this hot water has been purged from your UV Chamber. Do not allow water to contact your skin during this time. To eliminate this condition, a temperature management valve can be installed at the outlet of your UV System.</li><li>• Do not pass water through the UV System for a minimum of 5 minutes after applying power (including after power interruptions) to avoid passing under-treated water that may, in rare instances, pose health hazards.</li><li>• This system contains a UV Lamp Unit. Do not operate the UV Lamp Unit when it is removed from the UV Chamber. Unintended use or damage of the system may result in the exposure of dangerous UV radiation. UV radiation may, even in little doses, cause harm to the eyes and skin.</li><li>• Changes or modifications made to this system without the consent of the manufacturer could render the system unsafe for operation and may void the manufacturer's warranty.</li></ul>
---	---

	<p><b>WARNING:</b> This product can expose you to chemicals including phthalates, which is known to the state of California to cause cancer, and mercury, which is known to the State of California to cause birth defects or other reproductive harm. For more information go to <a href="http://www.P65Warnings.ca.gov">www.P65Warnings.ca.gov</a>.</p>
--	---

### **⚠ CAUTION**

 	<p>Failure to follow these instructions could result in minor or moderate injury.</p> <ul style="list-style-type: none"><li>• Carefully examine the UV System after installation. It should not be plugged in if there is water on parts not intended to be wet such as, the controller or lamp connector.</li><li>• <b>Hg EXPOSURE:</b> The UV Lamp Unit contains mercury. If the lamp breaks, then avoid inhalation or ingestion of the debris and avoid exposure to eyes and skin. Never use a vacuum cleaner to clean up a broken lamp as this may scatter the spilled mercury. Obey local regulations and guidelines for the removal and disposal of mercury waste.</li></ul>
--	--

## NOTICE

	<ul style="list-style-type: none"> <li>The Arros 9, Arros 15 and Arros 22 UV Systems have been validated through microbial testing. Through this testing, performance data has been generated for UV dose delivery to inactivate Cryptosporidium, Giardia, Escherichia coli (E. coli) and Fecal Coliform.</li> <li>The Arros 9-V, Arros 15-V and Arros 22-V UV Systems inactivate heterotrophs, Escherichia coli (E. coli) and Fecal Coliform.</li> </ul>
	<ul style="list-style-type: none"> <li>The UV Lamp Unit inside the UV System is rated at an effective life of approximately 9000 hours. To ensure continuous protection, replace the UV Lamp Unit annually.</li> <li>The UV System is not to be used or played with by children. Persons with reduced physical, sensory or mental capabilities, or lack of experience and knowledge, are also not to handle the UV System unless they have been given supervision or instruction.</li> <li>This system is intended to be permanently connected to the water lines.</li> <li>This system is not intended to be used in or above water or outdoors or used in swimming pools when persons are in the pool.</li> <li><b>EXTENSION CORDS:</b> If an extension cord is necessary, use only 3-wire extension cords that have 3-prong grounding-type plugs and 3-pole cord connectors that accept the plug from this system. Use only extension cords that are intended for outdoor use. Use only extension cords having an electrical rating not less than the rating of the system. A cord rated for less amperes or watts than this system rating may overheat. Exercise caution when arranging the cord so that it will not be tripped over or pulled. DO NOT use damaged extension cords. Examine extension cord before using and replace if damaged. DO NOT abuse extension cord. Keep extension cord away from heat and sharp edges. Always disconnect the extension cord from the receptacle before disconnecting this system from the extension cord. Never yank cord to pull plug from outlet. Always grasp the plug and pull to disconnect.</li> <li>If the supply cord is damaged, it must be replaced by a special cord or assembly available from the manufacturer or its service agent.</li> <li><b>SYSTEM PROTECTION:</b> To protect your Controller, a UL1449 certified (or equivalent) transient voltage surge suppressor is strongly recommended.</li> <li>The UV Lamp Unit in this system conforms to the applicable provisions of the Code of Federal Regulations (CFR) requirements including, Title 21, Chapter 1, Subchapter J, Radiological Health.</li> <li>Only the following Class B systems Arros 9-V, Arros 15-V and Arros 22-V or component conforms to NSF/ANSI 55 for the supplemental bactericidal treatment disinfected public drinking water or other drinking water that has been tested and deemed acceptable for human consumption by the state or local health agency having jurisdiction. The system is only designed to reduce normally occurring non-pathogenic nuisance microorganisms. Class B systems are not intended for treatment of contaminated water.</li> <li>Read and understand the Owner's Manual before operating and performing any maintenance on this equipment.</li> </ul>
	<ul style="list-style-type: none"> <li>This equipment has been tested and found to comply with the limits for a Class A digital device, pursuant to part 15 of the FCC Rules. These limits are designed to provide reasonable protection against harmful interference when the equipment is operated in a commercial environment. This equipment generates, uses, and can radiate radio frequency energy and, if not installed and used in accordance with the instruction manual, may cause harmful interference to radio communications. Operation of this equipment in a residential area is likely to cause harmful interference in which case the user will be required to correct the interference at his own expense.</li> <li>This equipment has been tested and found to comply with the limits for a Class B digital device, pursuant to part 15 of the FCC Rules. These limits are designed to provide reasonable protection against harmful interference in a residential installation. This equipment generates, uses and can radiate radio frequency energy and, if not installed and used in accordance with the instructions, may cause harmful interference to radio communications. However, there is no guarantee that interference will not occur in a particular installation. If this equipment does cause harmful interference to radio or television reception, which can be determined by turning the equipment off and on, the user is encouraged to try to correct the interference by one or more of the following measures:             <ul style="list-style-type: none"> <li>Reorient or relocate the receiving antenna.</li> <li>Increase the separation between the equipment and receiver.</li> <li>Connect the equipment into an outlet on a circuit different from that to which the receiver is connected.</li> <li>Consult the dealer or an experienced radio/ TV technician for help.</li> </ul> </li> <li>Changes or modifications not expressly approved by the party responsible for compliance could void the user's authority to operate the equipment.</li> </ul>

### 1.3 Water Chemistry

Water quality is extremely important for the optimum performance of your UV System. The following levels are recommended for installation:

Water Quality and Minerals	Level
Iron	< 0.3 ppm (0.3 mg/L)
Hardness*	< 7 gpg (120 mg/L)
Turbidity	< 1 NTU
Manganese	< 0.05 ppm (0.05 mg/L)
Tannins	< 0.1 ppm (0.1 mg/L)
UV Transmittance	> 75% (call factory for recommendations on applications where UVT < 75%)

\* Where total hardness is less than 7 gpg, the UV unit should operate efficiently provided the quartz envelope is cleaned periodically. If total hardness exceeds 7 gpg, the water should be softened. If your water chemistry contains levels in excess of those mentioned above, proper pre-treatment is recommended to correct these water problems prior to the installation of your UV System. These water quality parameters can be tested by your local dealer, or by most private analytical laboratories. *Proper pre-treatment is essential for the UV System to operate as intended.*

## Section 2 General Information

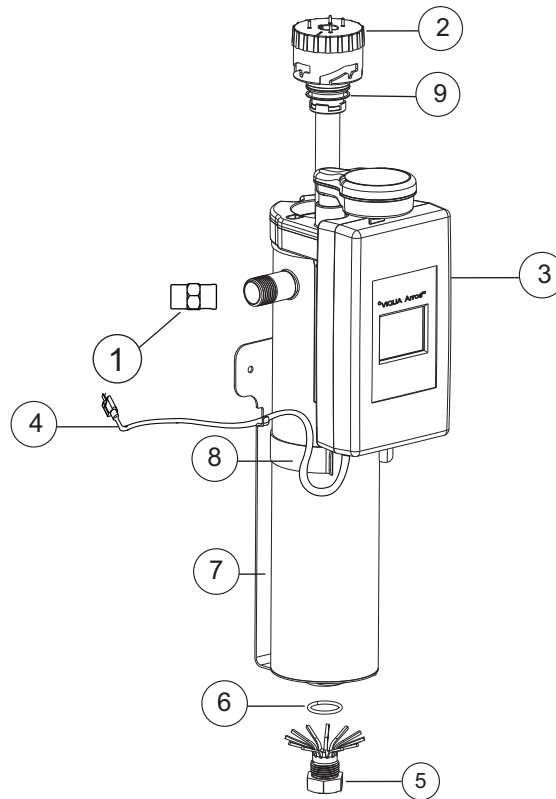

Figure 1 UV System Components

Item	Description	Part Number	UV Systems
1	Flow Restrictor (Only for certified systems)	FRSS-A9	Arros 9-V
		FRSS-A15	Arros 15-V
		FRSS-A22	Arros 22-V
2	UV Lamp Unit- Hard glass coated UV lamp for long consistent life (9000 hours) sealed within a GE 214 fused quartz sleeve	VA09LU	Arros 9, Arros 9-V
		VA15LU	Arros 15, Arros 15-V
		VA22LU	Arros 22, Arros 22-V
3	Arros Controller 100-240VAC/50/60Hz	VA-CTRL	All Models
4	Power Cords for Arros Controller	260251-R	Arros 9, Arros 15, Arros 22
		260252-R	Arros 9/2, Arros 15/2, Arros 22/2
		260253-R	Arros 9/WR, Arros 15/WR, Arros 22/WR
		260254-R	Arros 9/2A, Arros 15/2A, Arros 22/2A
5	Drain Plug	411111-R	All Models
6	Drain Plug O-ring	411138-R	All Models
7	Mounting Bracket Arros	420618-R	Arros 9 & Arros 15
	Mounting Bracket Arros	420624-R	Arros 22
8	Mounting Bracket Clamp	420619-R	All Models
9	Lamp Head O-ring	411173-R	All Models

## Section 3 Installation of UV System

### ⚠ CAUTION



Electronic Controller must be connected to a Ground Fault Protected Circuit (GFCI) receptacle. Ensure green ground wire ring terminal is securely fastened to ground stud on UV Chamber.

### 3.1 Installing UV System

The UV System is designed to be mounted either horizontally or vertically at the point-of-use or point-of-entry depending on the specific flow rate of the unit.

If installing the UV Chamber in horizontal position the outlet port must be pointing upwards to ensure all air is fully purged from the UV Chamber.

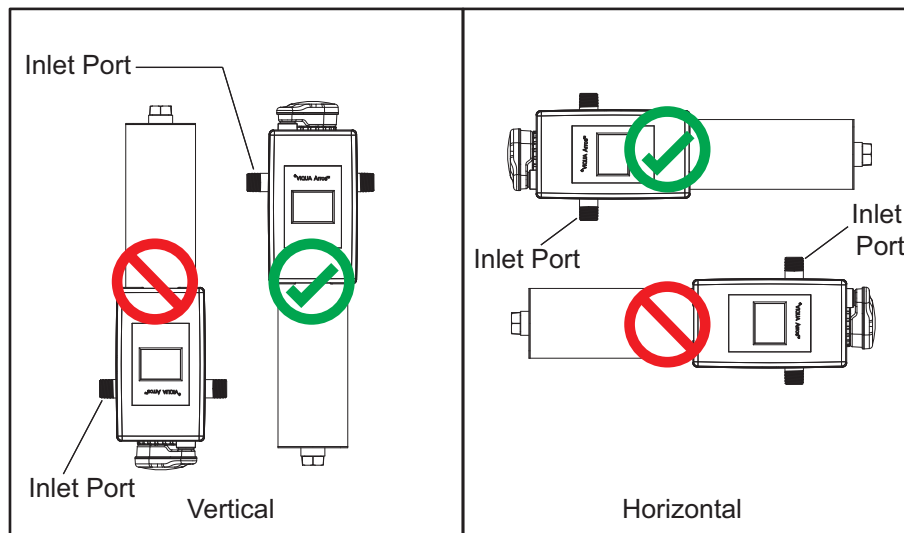

Figure 2 Installation - Vertical and Horizontal

**Note:** The preferred installation is vertical with the lamp connector on top. This is to prevent water damage from occurring on the lamp pins and lamp connector. If horizontal install is required ensure inlet port is positioned facing downward.

**Note:** To reverse inlet port to suit installation plumbing see [Section 3.1 procedure 4](#).

#### Prerequisites:

- Determine appropriate indoor location for the UV System. Refer to [Figure 3](#).
- Ensure adequate clearance above UV Chamber to allow for removal of the UV Lamp Unit.
- Make sure to turn off the main water supply and depressurize the line.
- Mount the system to the wall with appropriate lag bolts through the two mounting holes located on the metal bracket.
- The supplied lag bolts are suitable for attachment to wood.

**Note:** Attachments to other materials will require purchasing of alternative hardware.

- Make all necessary plumbing connections. Refer to [Figure 3](#).

## Installation of UV System

### Procedure:

- Figure 3 shows the installation of a typical UV System and the related components that may be used for the installation. The use of a by-pass assembly is recommended in case the system requires “off-line” maintenance. In this case, note the system requires a supplementary disinfectant for the distribution system if any water is used during by-pass condition. In addition, during by-pass, the water will NOT be treated and a “DO NOT CONSUME THE WATER” tag should be physically installed on the by-pass assembly until such time as the system is sanitized and returned to service. For more information, refer to Section 3.2. If the water is to be consumed while the system is off-line, the water must be boiled for twenty minutes prior to consumption.

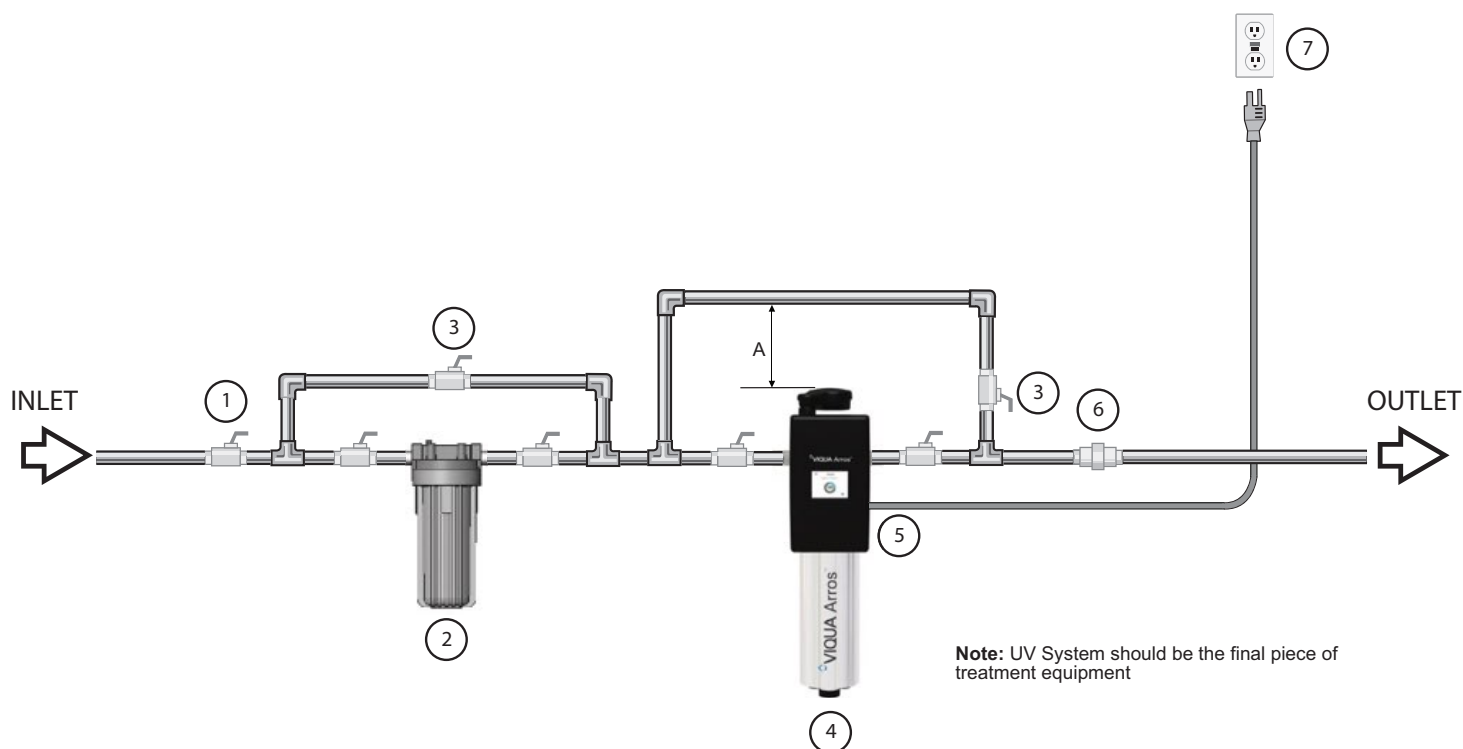

Figure 3 UV System

Item	Description	Item	Description
1	Main water shut-off	5	UV System
2	Filter Cartridge	6	Optional flow restrictor <b>Note: Mandatory for NSF credited systems</b>
3	Optional by-pass assembly	7	Customer supplied GFCI circuit to match voltage
4	Drain Plug		
A	<b>Note:</b> By-pass pipe should be at least 6" above the Arros UV unit and as close to the wall as possible to ensure lamp can be removed.		

- Select a suitable location for the UV System and its related components. As it is recommended to install a GFCI, make sure that this is taken into consideration prior to any installation. The system can either be installed vertically as shown in Figure 4 A, or horizontally as shown in Figure 4 B. However, the vertical installation is the most preferred method. When selecting a mounting location, leave enough space to allow the removal of the UV Lamp Unit (typically leave a space equal to the size of the UV Chamber itself).

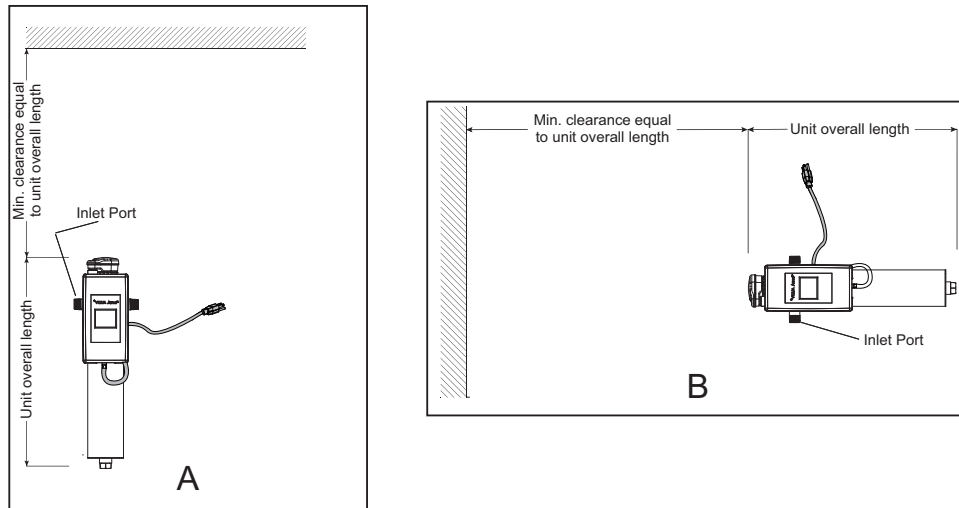

Figure 4 UV System Installation - Vertical and Horizontal

3. Mount the system to the wall using the supplied bracket. Various connection methods can be used to connect the water source to the system, however union type connectors are recommended. For validated systems, the use of a flow restrictor device will help to maintain the manufacturers rated flow. The flow restrictor should be installed on the outlet port and is designed to be installed in one direction only. Ensure that the flow of the water matches the flow direction as indicated on the flow restrictor. Refer to [Figure 5](#).

**Note:** DO NOT solder connections while attached to the system as this could damage the O-ring seals.

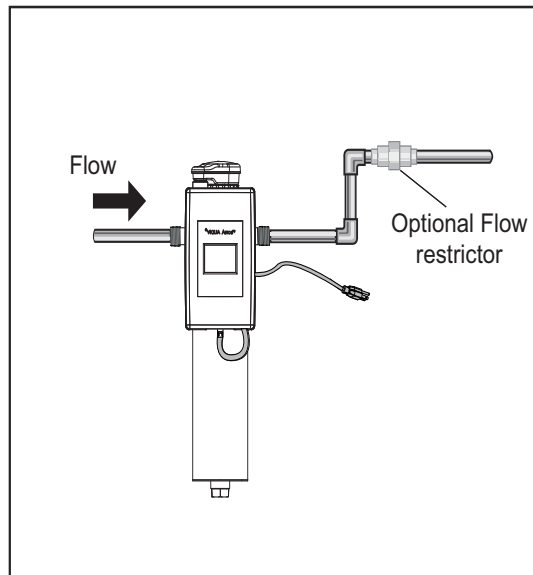

Figure 5 Flow Restrictor

## Installation of UV System

### 4. Reversing the inlet and outlet ports.

**Note:** If reversal of UV System ports is not required, skip this step and proceed to Step 5.

The factory configuration of the UV System is with the inlet port on the left side of the unit. If required due to plumbing installations then this can be reversed as follows:

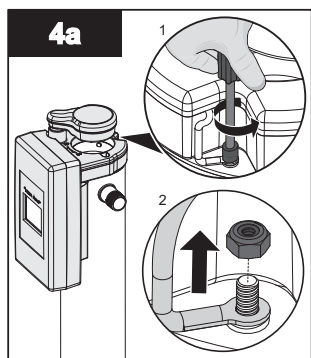

- Remove the locknut found on the back side of the UV System.

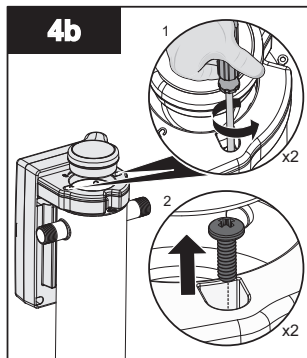

- Remove the two Phillips screws that attach the controller unit to the UV Chamber.

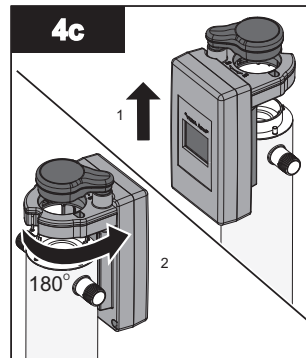

- Pull the controller off of the UV Chamber and rotate it 180 degrees.

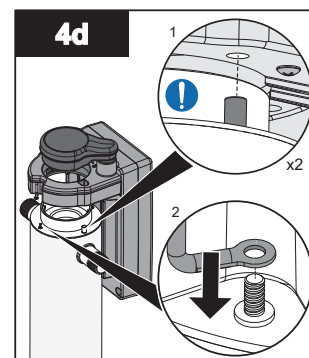

- Align the mounting holes on the controller with the welded #10 stud mounts on the UV Chamber and insert the ground wire back onto the threaded stud.

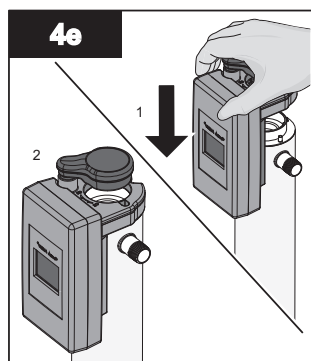

- Push the controller firmly down onto the UV Chamber.

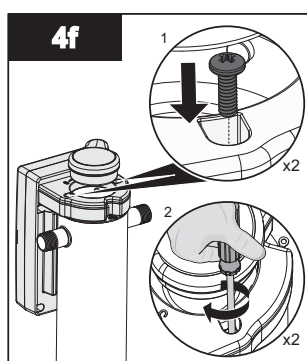

- Reassemble the mounting screws to secure the controller to the UV Chamber

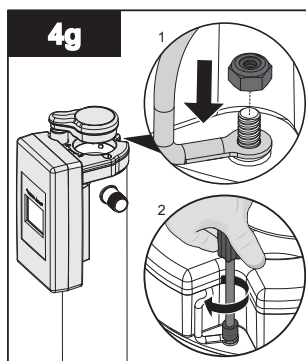

- Tighten down the locking nut to secure the grounding wire.

### 5. Install the UV Lamp Unit into the UV Chamber. Twist UV Lamp Unit until fully seated then swing lamp connector around and position over top of the lamp and press down until the lamp pins are fully inserted into the lamp connector.

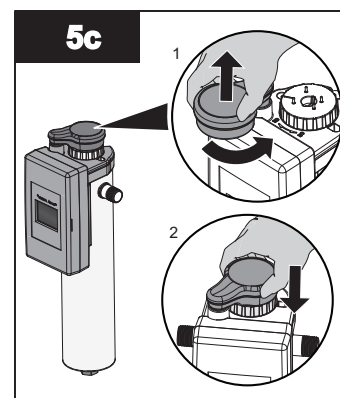
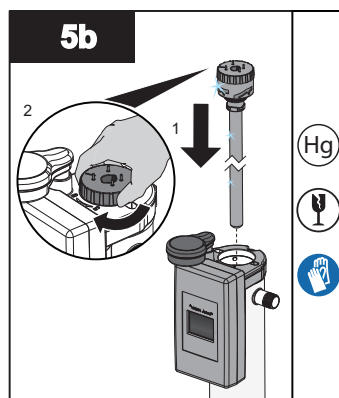
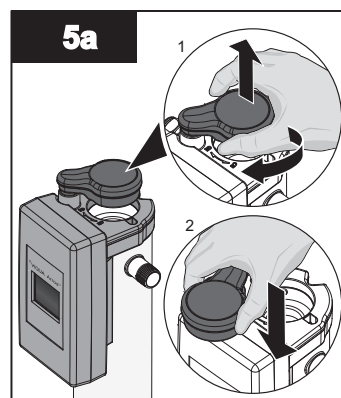

- When all plumbing connections are complete, slowly turn on the water supply and check for leaks. The most likely cause of leaks is from the O-ring seals in either the UV Lamp Unit or the drain plug. To resolve, shut water off and drain the UV Chamber. Remove either the UV Lamp Unit or drain plug, as needed and wipe the O-rings and threads. Clean and re-install. Once it is determined that there are no leaks, plug the system into the ground fault interrupter and check controller to ensure the system is operating properly. The controller should illuminate without any alarms.

**Notes:** 1) Use a wrench to tighten the drain plug. DO NOT over-tighten.

2) It is normal for the drain plug to make a clicking sound during install.

- Allow the water to run for a few minutes to clear any air or dust that may be in the UV Chamber.

**Note:** When there is no flow, the water in the UV Chamber will become warm. To remedy this, run a cold water tap anywhere in the house for a minute to flush out the warm water.

- Once it is determined that there are no leaks, plug the system into the ground fault interrupter and check controller to ensure the system is operating properly. The controller should illuminate without any alarms.

**Note:** DO NOT look directly at the glowing UV Lamp Unit.

## 3.2 Cleaning Procedure

It is imperative that the entire distribution system located after the UV System be chemically cleaned to ensure that the plumbing system is free from any contaminants. The cleaning process must be performed immediately after the UV unit is installed and repeated thereafter whenever the UV System is shut down for service, without power, or inoperative for any reason. The procedure for sanitizing the plumbing system is readily accomplished as follows:

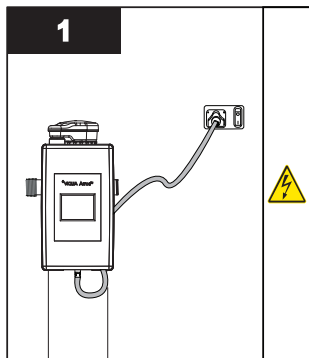

- Ensure that the unit remains powered on for the entire cleaning process.

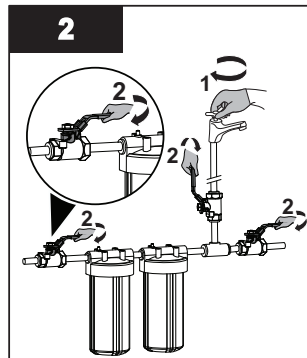

- Shut off the water supply.
- Close each faucet.

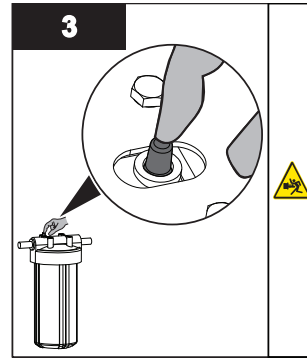

- Press the pressure button to release the pressure from the cartridges.

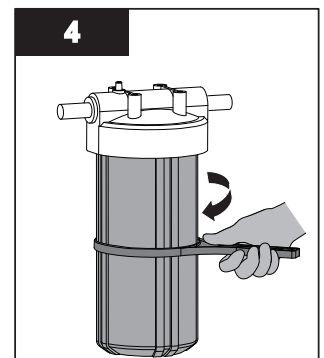

- Remove sump housing(s) using sump wrench.

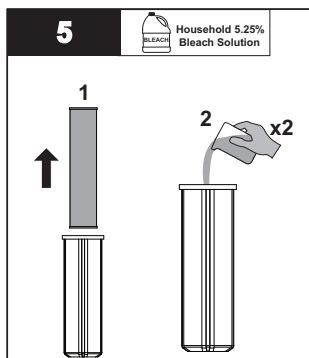

- Remove cartridge(s) and pour 2 cups of household bleach solution into the filter housing(s).

**Note:** DO NOT use Hydrogen Peroxide.

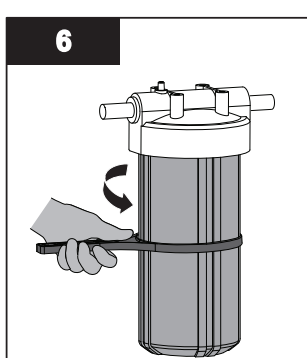

- Reinstall sump only to filter head.

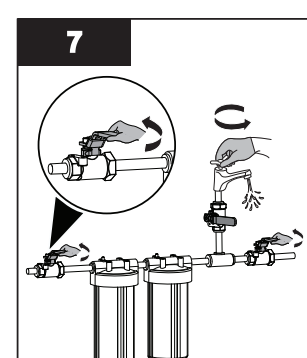

- Turn on water supply.
- Open a tap down stream and allow water to fill the UV Chamber until you smell bleach.

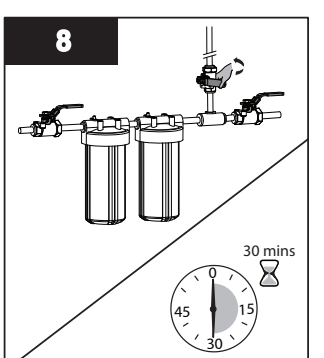

- Turn on the cold water supply followed by hot water (if available) until you smell the bleach.
- Close all faucets and allow bleach to settle in the water lines for 30 minutes.

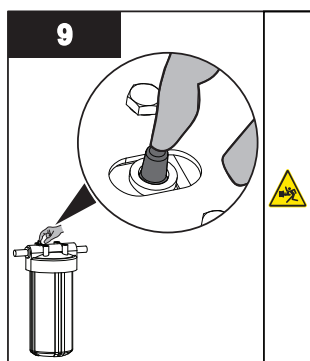

- Shut off the water supply.
- Press the pressure button to release the pressure.

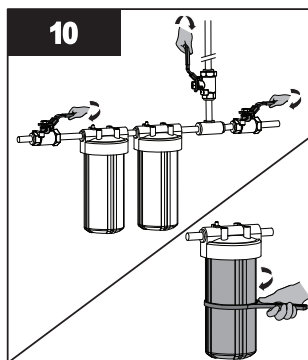

- With all faucets closed, remove filter housing(s) using sump wrench.

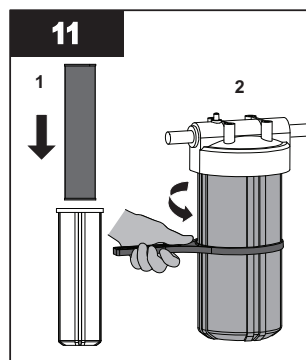

- Reinstall the cartridge(s) into filter housing(s) and connect to the unit.
- Turn on water supply and flush all water outlets until bleach can no longer be smelled (at least 5 minutes).



- Press the pressure button to purge air and to complete the cleaning procedure.
- Inspect for any leaks.
- Repair all detected leaks.

**Notes:** 1) The addition of chlorine (bleach) to a hot water tank that has in the past been fed with untreated raw water with high levels of other contaminants (iron, manganese, hydrogen sulphide, organics, etc.) will result in oxidation of these contaminants and may require repeated flushing of the hot water tank. This contingency must be dealt with independently under the start-up procedure for any other conditioners that may form a part of the pre-treatment for the UV unit.

2) The above cleaning procedure will result in a massive chlorine residual far in excess of the 0.5 to 1.0 mg/L typically present in municipally chlorinated water and of a magnitude consistent with the minimum 50 mg/L chlorine solution recommended for the cleaning of distribution systems known to be contaminated. Do not consume water until complete system has been flushed.

## Section 4 Maintenance

### ⚠ WARNING



- Always disconnect power before performing any work on the UV System.
- Always shut-off water flow and release water pressure before servicing.
- Regularly inspect your UV System to ensure that the power indicators are on and no alarms are present.
- Replace the UV Lamp Unit annually upon controller alert, typically after 1 year or 9000 hours of operation.
- Always drain the UV Chamber when closing a seasonal home or leaving the unit in an area subject to freezing temperatures.

## 4.1 Remove and Install a UV Lamp Unit

### NOTICE

- Refer to [www.lamprecycle.org](http://www.lamprecycle.org) for lamp disposal.
- DO NOT use water during replacement of UV Lamp Unit.

UV Lamp Unit replacement is a quick and simple procedure requiring no special tools. The UV Lamp Unit must be replaced after 9000 hours of continuous operation (approximately one year) in order to ensure adequate performance.

#### Procedure:

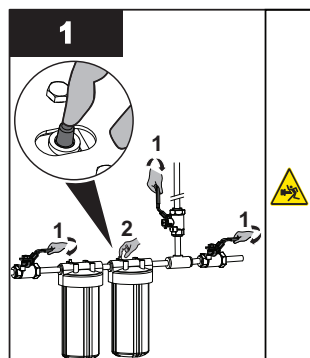

- Shut off the water supply.
- Close each faucet.
- Press the pressure button to release the pressure from the cartridges.

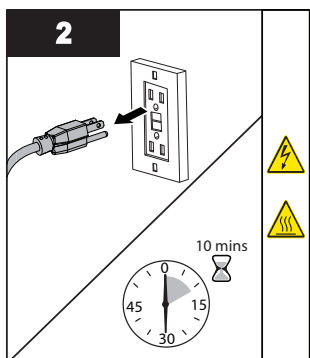

- Disconnect main power source and allow the unit to cool for 10 minutes.

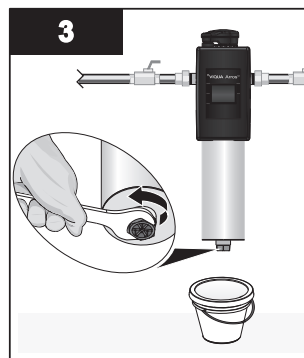

- Loosen the drain plug at the bottom of the UV Chamber and place a pail to catch the water.



- To remove lamp connector from the UV Lamp Unit, pull lamp connector straight up until the pin sockets disengage from the UV Lamp Unit pins.
- Rotate lamp connector clockwise until a stop is hit. Then press down to lock in the service position.

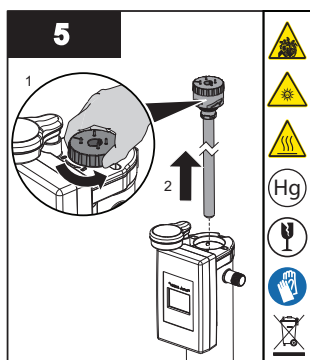

- To remove UV Lamp Unit, rotate counter clockwise until the UV Lamp Unit becomes free from the bayonet mounting taps.
- Carefully pull UV Lamp Unit straight out from UV Chamber ensuring the UV Lamp Unit does not contact the UV Chamber.
- Always hold the UV Lamp Unit by the plastic lamp head.

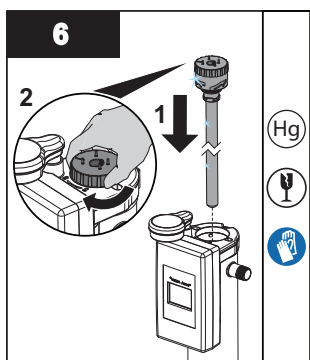

- Insert the new UV Lamp Unit fully into the UV Chamber and rotate clockwise until lamp is fully inserted and aligns with the lock position shown on the controller top.

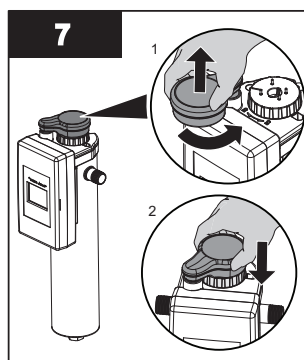

- Rotate lamp connector counter clockwise from the service position so it is over top of the UV Lamp Unit connector pins.
- Press down until the lamp connector fully engages the UV Lamp Unit pins.

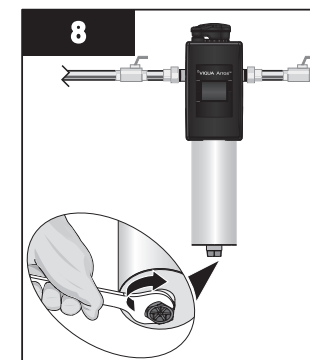

- Tighten the drain plug, using a wrench. DO NOT over-tighten.

**Note:** It is normal for the drain plug to make a clicking sound during install.

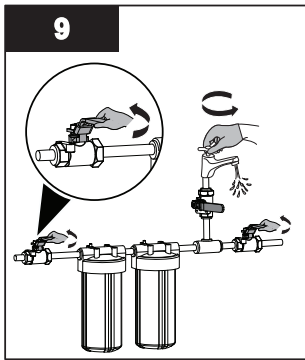

- Open each faucet and turn on water supply.
- Inspect for any leaks.
- Repair all detected leaks.

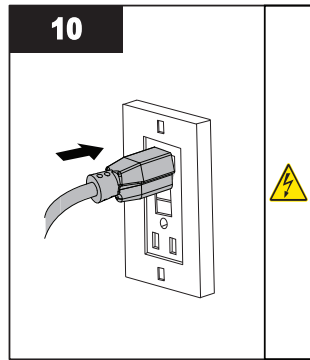

- Reapply power to the UV System. The End of Lamp timer should now show 365 days remaining.
- Perform the cleaning procedure. Refer to [Section 3.2](#).

## 4.2 Cleaning Lamp Unit Assembly Quartz Envelope

Minerals in the water slowly form a coating on the quartz envelope. This coating must be removed because it reduces the amount of UV light reaching the water, thereby reducing performance. If the envelope cannot be cleaned the UV Lamp Unit assembly must be replaced.

### Prerequisites:

- Shut off water supply and drain all lines.
- Depressurize the UV System.
- Remove the UV Lamp Unit. Refer to [Section 4.1](#), Steps 1 through 5.

### Procedure:

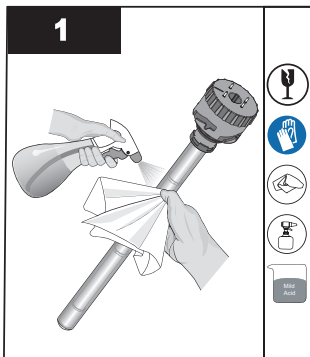

- Clean the quartz envelope with a cloth soaked in CLR, vinegar or some other mild acid and then rinse with water.

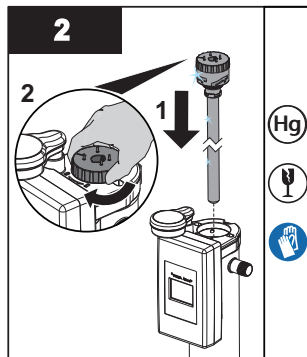

- Insert the cleaned UV Lamp Unit fully into the UV Chamber and rotate clockwise until UV Lamp Unit is fully inserted and aligns with the lock position shown on the controller top.

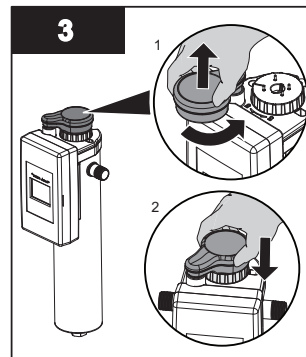

- Rotate lamp connector counter clockwise from the service position so it is over top of the UV Lamp Unit connector pins.
- Press down until the lamp connector fully engages the UV Lamp Unit pins.

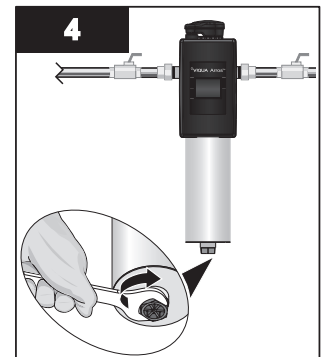

- Tighten the drain plug, using a wrench. DO NOT over-tighten.  
**Note:** It is normal for the drain plug to make a clicking sound during install.

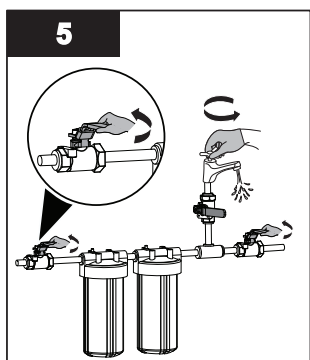

- Open each faucet and turn on water supply.
- Inspect for any leaks.
- Repair all detected leaks.
- Perform the cleaning procedure. Refer to [Section 3.2](#).

## Section 5 Operations

### ⚠ WARNING



The advanced warning system has been installed to provide the optimum protection against microbiological contamination in water. DO NOT disregard the warning signals. The best way to ensure optimum UV performance is to have the water microbiologically tested by a recognized testing agency on a regular basis.

### 5.1 UV System Operation

*Note: Firmware updates may modify the UI screens and processes. If necessary, refer to the online manual for most up-to-date information.*

*Note: The factory default settings on the Controller are as follows, Language = English; LCD Orientation = Vertical. Default settings can be changed in the [Settings Screen](#).*

### 5.2 Home Screen

1. The Home Screen displays the lamp life remaining and counts down from 365 to 0 days as the system is ON.
2. The Home Screen also displays Lamp Status ON/OFF, indicated by the sun symbol in the bottom right hand corner of the screen.

Symbol	Color	Description
	Cyan	Lamp On
	Black	Lamp Off

3. A Minor Warning Alarm is initiated once the lamp life reaches 30 days remaining and will also alarm when the lamp life reaches 14 days remaining.

## Operations

4. A Major Lamp Alarm will be initiated once the lamp life reaches 0 days.

**Notes:** 1) The UV System Wi-Fi capability is for firmware updates only ([Section 5.4](#)) and is not capable of system status or control.

2) Use of a non-VIQUA UV Lamp Unit will result in an ongoing fault mode (minor lamp alarm), including an audible beep every 60 seconds and will impair accurate lamp-life tracking.



Lamp On

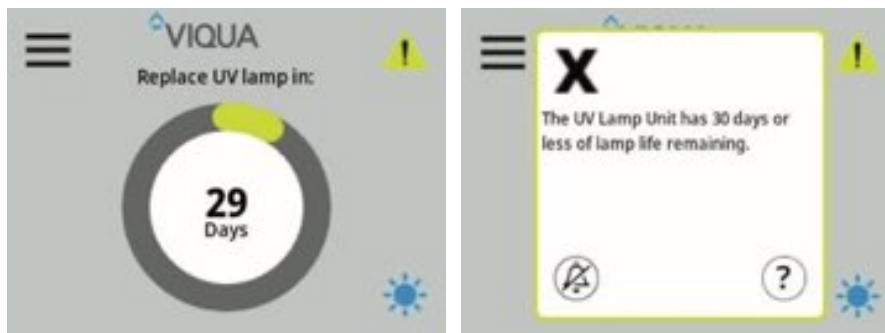

Minor Alarms

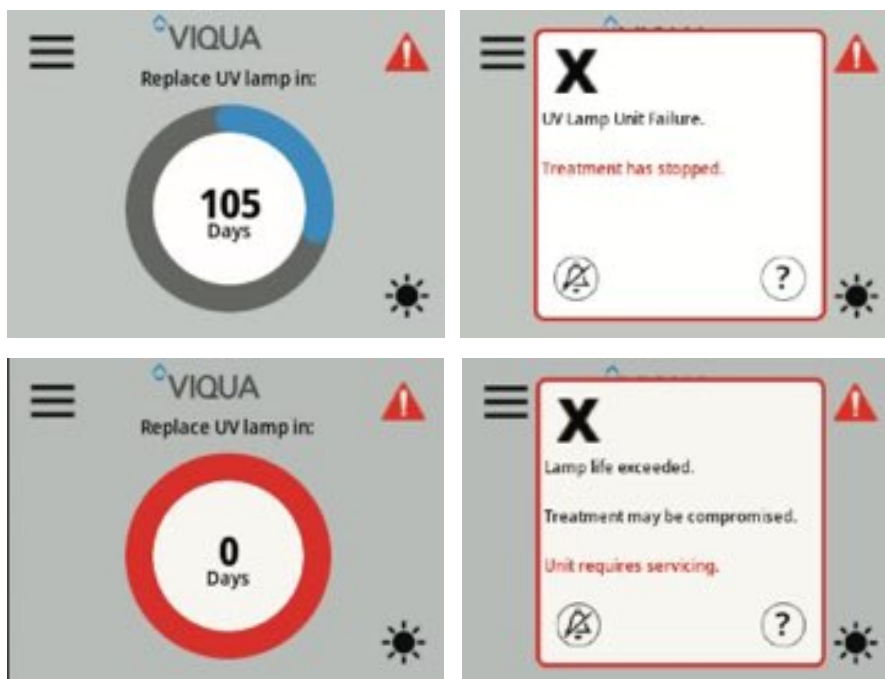

Major Alarms Lamp Fault/Lamp Life expired

Figure 6 Home Screen

## 5.3 Menu Screen

1. From the Home Screen, press the top left  icon to access the Menu Screen.
2. The Menu Screen provides access to four main user screens, Spare Parts, Contact, Information and Settings:

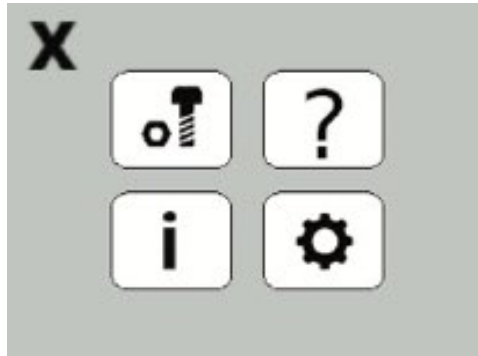

Figure 7 Menu Screen

### 5.3.1 Parts Screen

The Parts Screen displays the common replacement part numbers for the UV System.

**Note:** *The replacement parts displayed will be for the system model configured during the setup at the factory and is configurable on the Settings Menu.*

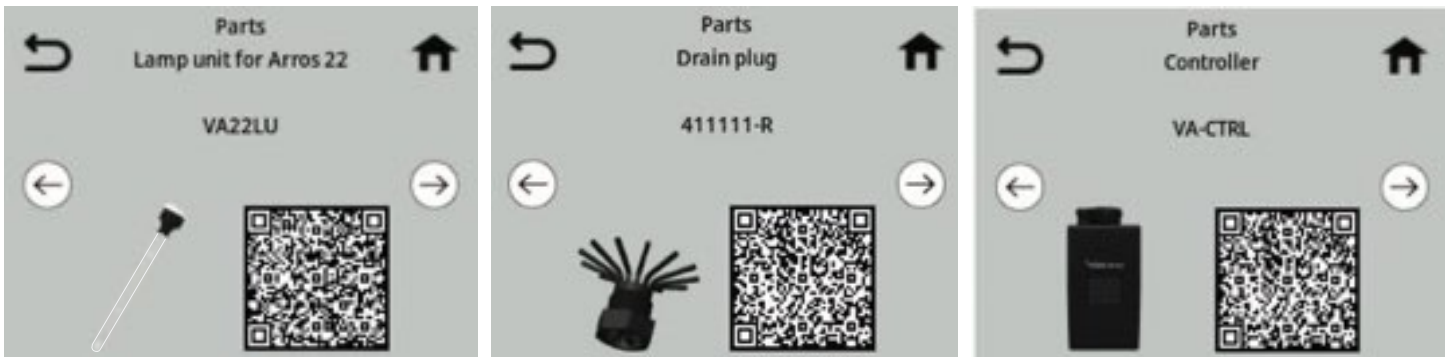

Figure 8 Parts Screen

### 5.3.2 Settings Screen

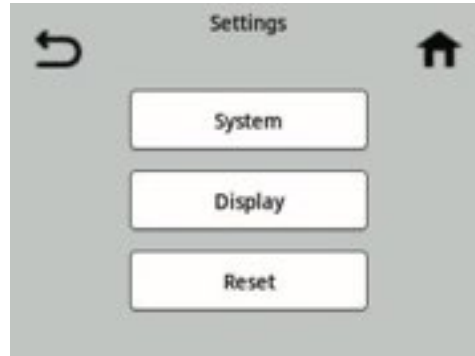

Figure 9 Settings Menu

The Settings Screen allows users to change the following settings:

Button	Setting
System	Language - Set the user interface language, choose from English, French or Spanish
	Model Number - Preset at the factory
Display	Screen Brightness - Move the brightness slider to increase or decrease the LCD Screen brightness
	Halo Brightness - Move the brightness slider to increase or decrease the Lamp Head Status Lights brightness ( <a href="#">Section 5.3.2.2</a> ).
	Screen Saver Time - Adjust the screen saver time
	User Interface Orientation ( <a href="#">Section 5.3.2.1</a> ) <ul style="list-style-type: none"> <li>• Vertical, select for vertical UV Chamber install orientation</li> <li>• Horizontal, select for horizontal UV Chamber install orientation</li> </ul>
Reset	Select to return all settings back to the factory defaults

#### 5.3.2.1 Display Setting - User Interface Orientation

When mounting the UV System in a horizontal installation the LCD Screen can be configured to the most preferred orientation. Press the arrows to change the LCD Screen orientation. Once desired orientation is shown press the Home button.

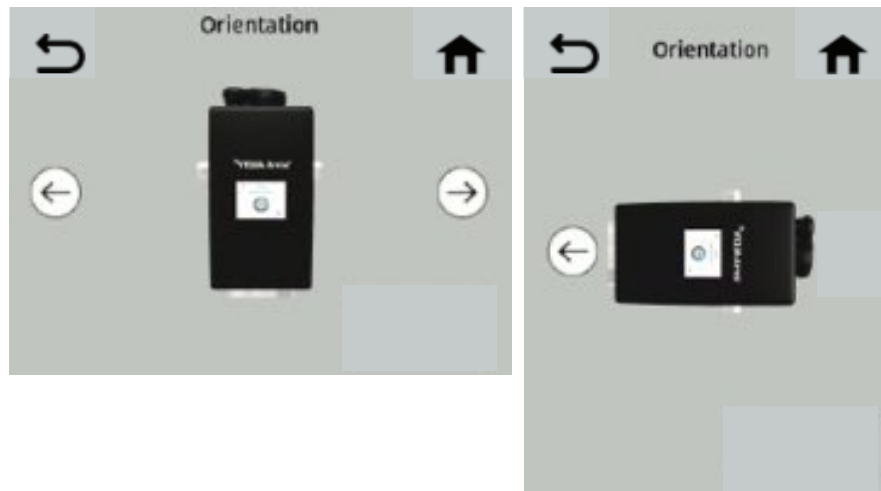

Figure 10 LCD Screen Orientation

### 5.3.2.2 Lamp Head Status Lights

The white top cap (Halo) of the lamp assembly will illuminate when the lamp is operating. For normal operation (no faults, lamp on) the caps is blue. When there is a minor alarm condition (lamp life less than 30 days left), the top cap is amber. When there is a major alarm condition, the cap will be red.

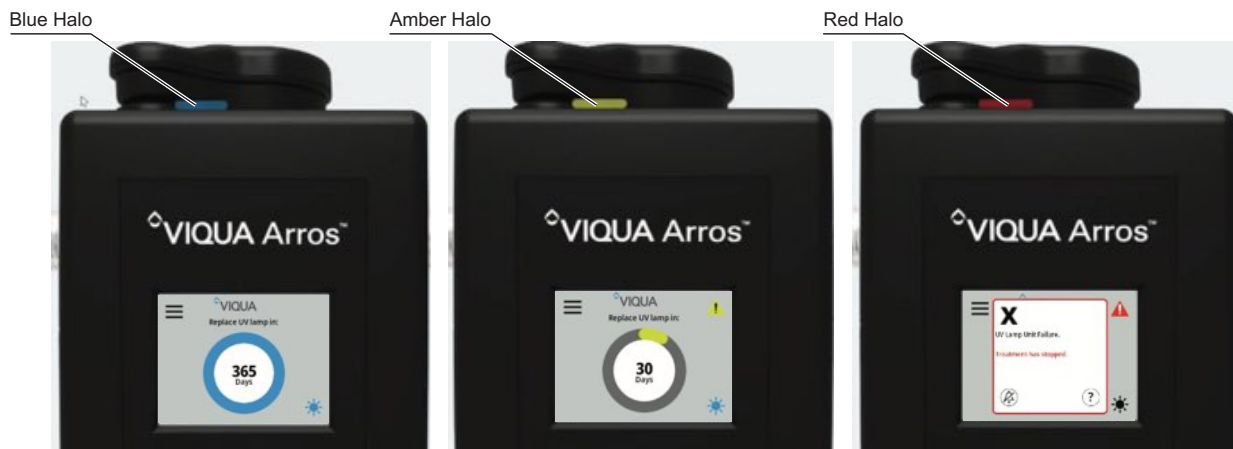

Figure 11 Lamp Head Status Lights

### 5.3.3 Information Screen

Information menu which provides system information including Model number, Firmware revision, Model number, Lamp serial number and Controller serial number. Additionally, it provides access to register the UV System and find a dealer in your area.



Figure 12 Information Screen, Register Screen and Contact Screen

Button	Setting
Register	Select to display the Register Screen that displays a QR code to complete the online registration. Scan the QR code to go to <b>viqua.com/register</b> to register your system, to receive important updates about the UV System, including UV Lamp replacement reminders
Contact	Select to display the Contact Screen that displays a QR code to find a dealer near you. Scan the QR code to go to <b>viqua.com/where-to-buy</b> to find a service and replacement parts dealer in your area.

## 5.4 Firmware Updates

Firmware updates are released periodically to enhance the performance or add features to the controller. New firmware can be uploaded to the controller using the VIQUA App from a smart phone or tablet.

Scan the QR code or click the link below to download the VIQUA App:



Figure 13 iOS Devices



Figure 14 Android Devices

For more details on the VIQUA App, go to: [www.viqua.com/arros](http://www.viqua.com/arros).

## Section 6 Troubleshooting

Alarm	Description	Possible Cause	Troubleshooting
UV Lamp Unit Failure.	UV Lamp Unit Failure. Treatment has stopped.	<ol style="list-style-type: none"> <li>1 UV Lamp Unit connection.</li> <li>2 UV Lamp Unit failed.</li> </ol>	<ol style="list-style-type: none"> <li>1 Disconnect UV System from power supply.</li> <li>2 Check for secure lamp connection.</li> <li>3 Restore power to UV System.</li> <li>4 If failure repeats, replace UV Lamp Unit. Refer to <a href="#">Section 4.1</a>.</li> </ol>
			<b>Silencing:</b> The Lamp Fault audible alarm can be silenced for 24 hours at a time up to 7 times.
Controller Failure.	Controller Failure. Controller Requires Servicing. Treatment has stopped.	<ol style="list-style-type: none"> <li>1 Incorrect power supply.</li> <li>2 Unreliable power supply.</li> <li>3 Power supply connection.</li> <li>4 Controller failed.</li> </ol>	<ol style="list-style-type: none"> <li>1 Disconnect UV System from power supply.</li> <li>2 Ensure power supply is reliable and matches controller ratings.</li> <li>3 Restore power to UV System.</li> <li>4 If failure repeats with a correct and reliable power supply, replace Controller.</li> </ol>
			<b>Silencing:</b> The Controller Fault audible alarm can be silenced for 24 hours at a time up to 7 times.
Over temperature	Over temperature detected. Treatment has stopped.	<ol style="list-style-type: none"> <li>1 Room temperature too high.</li> <li>2 Heat source near treatment system.</li> <li>3 No water in the treatment system.</li> <li>4 Water temperature too high.</li> </ol>	<ol style="list-style-type: none"> <li>1 Wait for UV treatment system to cool down.</li> <li>2 When UV System has cooled down enough it will automatically restart.</li> <li>3 If failure repeats, check for and remove source of heat near treatment system.</li> <li>4 If failure repeats, ensure room temperature is below maximum rating for treatment system.</li> <li>5 If failure repeats, check if the treatment system has water in it.</li> <li>6 If failure repeats, check if the water temperature is below the maximum rating for the treatment system.</li> </ol>
			<b>Silencing:</b> The over temperature audible alarm can be silenced for 24 hours at a time up to 7 times.
Lamp Life Exceeded	Lamp life exceeded. Treatment may be compromised. Unit requires servicing.	UV Lamp Unit life exceeded.	Replace UV Lamp Unit. Refer to <a href="#">Section 4.1</a> .
			<b>Silencing:</b> The UV Lamp Unit life exceeded audible alarm can be silenced for 7 days at a time up to 4 times.

Alarm	Description	Possible Cause	Troubleshooting
Lamp Data Fault	Lamp data fault. Lamp days are unavailable. Treatment may be compromised.	<ol style="list-style-type: none"> <li>UV Lamp Unit connection.</li> <li>UV Lamp Unit failed.</li> </ol>	<ol style="list-style-type: none"> <li>Disconnect UV System from power supply.</li> <li>Check for secure lamp connection.</li> <li>Restore power to UV System.</li> <li>If failure repeats, replace UV Lamp Unit. Refer to <a href="#">Section 4.1</a>.</li> </ol>
	<b>Silencing:</b> The Lamp Data Fault audible alarm can be silenced for 7 days at a time up to 4 times.		
Lamp Life - 30 Days	The UV Lamp Unit has 30 days or less of lamp life remaining	UV Lamp Unit within one month to end of life.	Replace UV Lamp Unit before zero days remaining. Refer to <a href="#">Section 4.1</a> .
	<b>Silencing:</b> The UV Lamp Unit below 31 days audible alarm can be silenced for 14 days at a time up to 2 times.		
Lamp Life - 14 Days	The UV Lamp Unit has 14 days or less of lamp life remaining	UV Lamp Unit less than two weeks to end of life.	Replace UV Lamp Unit before zero days remaining. Refer to <a href="#">Section 4.1</a> .
	<b>Silencing:</b> The UV Lamp Unit below 15 days audible alarm can be silenced for 7 days at a time up to 2 times.		

Symptom	Possible Cause	Possible Solution
No Power	GFCI and or circuit breaker has tripped	Reset GFCI and or circuit breaker
	Transient voltage surge suppressor damaged	Replace TVSS
	Controller damaged	Replace controller and use a TVSS
GFCI or circuit breaker repeatedly trips	Connection between lamp and lamp plug is wet	Clean and dry area around the lamp and lamp connector, check unit for leaks or condensation
	Short circuit in electrical assembly	Replace controller
Leak at inlet or outlet	Threaded pipe fittings are leaking	Clean threads, reseal with Teflon tape and re tighten
Leak detected from area of UV Chamber	Condensation of warm moist air on cold UV Chamber (slow accumulation)	Control humidity or relocate unit
	O-rings damaged, deteriorated or incorrectly installed	Inspect o-rings and replace if deteriorated.
	UV Lamp Unit not properly installed (not fully inserted into controller lamp locking assembly)	Tighten and ensure lamp assembly is fully inserted into controller locking assembly
Alarm	Refer to Alarm Menu ( <a href="#">Section 6</a> )	Follow alarm menu help guidance
System is operating but water tests reveal bacterial contamination	Equipment downstream of UV System is acting as a breeding ground for pathogens	Ensure UV is the last piece of treatment equipment
	Pathogens are residing in the distribution lines post UV	Ensure all distribution lines have been disinfected with chlorine. Refer to <a href="#">Section 3.2</a> .
	Recontamination from pipe dead-ends	Remove any pipe dead-ends and flush with chlorine. Refer to <a href="#">Section 3.2</a> .
Pressure Drop	Sediment Pre-Filter clogged	Replace filter cartridge with appropriate 5 micron cartridge. Note: Check source water supply as fluctuations may occur in source pressure
	Flow regulator	Flow regulator will result in pressure drop when approaching full flow.
High Bacteria Counts	UV Lamp Unit quartz envelope is stained or dirty	Clean quartz envelope of UV Lamp Unit with scale cleaner and eliminate the source of staining problem (i.e soften hard water) Refer to <a href="#">Section 4.2</a> .
	Change in feed water quality	Have source water tested to ensure that water quality is still within allowable limits for this system.
	Contamination in water lines after UV System	It is imperative that effluent water stream be shocked with chlorine (bleach) before water leaves UV System - the system must have a bacterial free distribution system to work effectively. Refer to <a href="#">Section 3.2</a> .
	Possible break-through of sediment through pre-filter	Have source water tested for turbidity- may need stepped filtration in order to catch all sediment entering water system (20 micron filter followed by a 5 micron filter followed by the UV System)
Heated Product Water	Common problem caused by infrequent use of water	Run water until it returns to ambient temperature
Water Appears Milky	Caused by air in the water lines	Run water until air is purged
Unit Leaking Water	Problem with O-ring seal on Lamp Assembly or Drain Plug Assembly	Ensure O-ring is in place, check for any cuts or abrasions, clean O-ring, moisten with water/lubricant and re-install, replace if necessary
	Condensation on UV Chamber caused by excessive humidity and cold water	Check location of UV System and control humidity
	Inadequate inlet/outlet port connections	Check thread connections, reseal with Teflon tape and re-tighten connection

## Manufacturer's Dose Flow Chart

Symptom	Possible Cause	Possible Solution
System shutting down intermittently	Interrupted Controller	Ensure system has been installed on its own circuit as other equipment may be drawing power away from UV (ie pump or fridge) UV System should not be installed on a circuit which is incorporated into a light switch
Lamp Failure Alarm on New Lamp	Loose connection between lamp and lamp connector	Disconnect lamp from connector and reconnect, ensuring that a tight fit is accomplished
	Moisture build up in connector may keep lamp and connector from making a solid connection	Eliminate chance of any moisture getting to the connector and/or lamp pins

## Section 7 Manufacturer's Dose Flow Chart

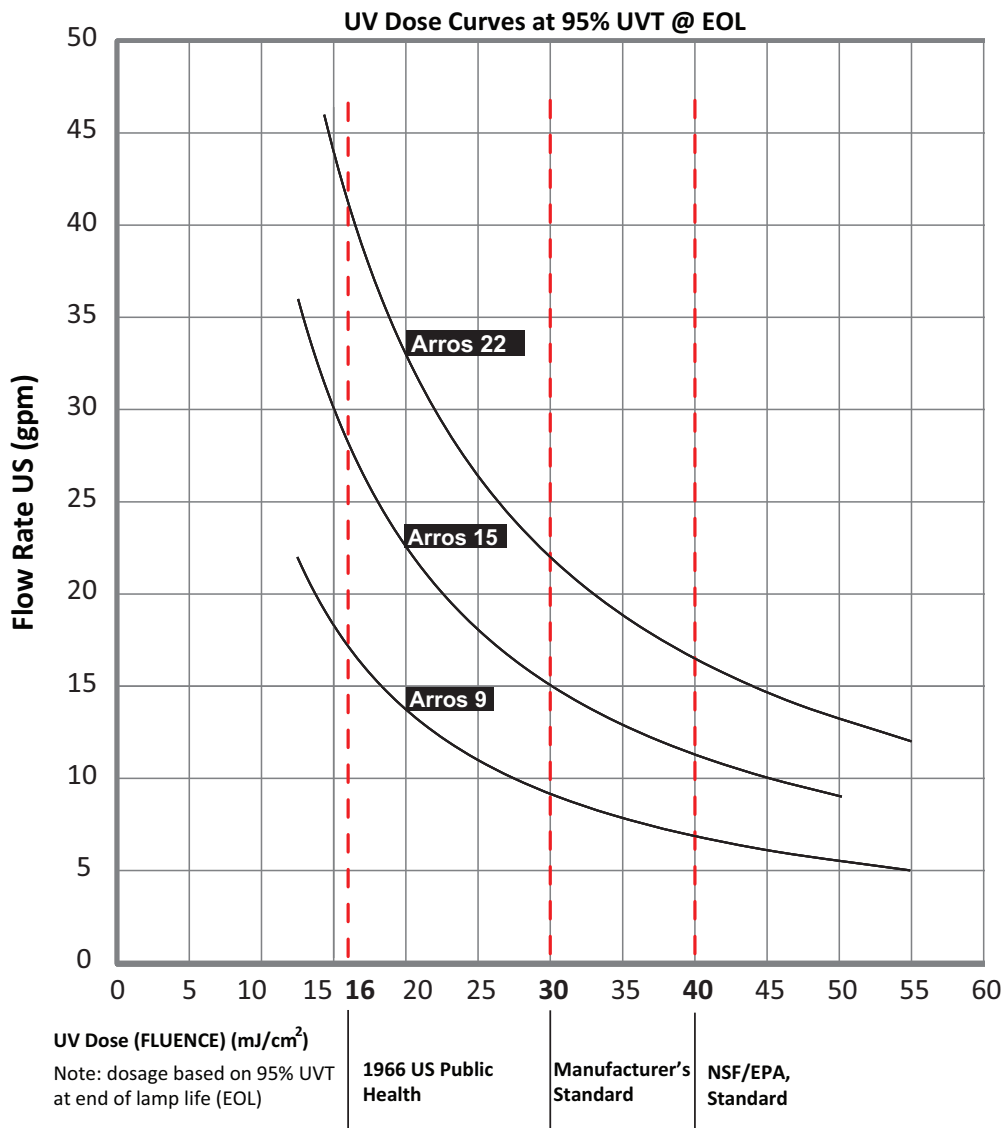

Note: Not performance tested or certified by NSF

Figure 15 Dose Flow Chart

*NSF Standard 55 Class B Certified Systems*

Model	Flow Rate	Min Dose @ 70% UVT
Arros 9-V	6.4 gpm	16 mJ/cm <sup>2</sup>
Arros 15-V	9.4 gpm	16 mJ/cm <sup>2</sup>
Arros 22-V	12.9 gpm	16 mJ/cm <sup>2</sup>

**Note:** Performance tested or certified by NSF

## Section 8 Specifications

Model		Arros 9	Arros 9-V	Arros 15	Arros 15-V	Arros 22	Arros 22-V
Flow Rate <sup>1</sup> Not performance tested or certified by NSF	*NSF class B certified 16mJ/cm <sup>2</sup> @70% UVT	6.4 gpm (24.2 lpm) (1.45 m <sup>3</sup> /hr)		9.4 gpm (35.58 lpm) (2.13 m <sup>3</sup> /hr)		12.9 gpm (48.8 lpm) (2.93 m <sup>3</sup> /hr)	
	US Public Health 16mJ/cm <sup>2</sup> @ 95%UVT	17 gpm (64.3 lpm) (3.86 m <sup>3</sup> /hr)		29 gpm (109.8 lpm) (6.59 m <sup>3</sup> /hr)		42 gpm (159 lpm) (9.54 m <sup>3</sup> /hr)	
	VIQUA Standard 30mJ/cm <sup>2</sup> @ 95%UVT	9 gpm (34.1 lpm) (2.0 m <sup>3</sup> /hr)		15 gpm (56.8 lpm) (3.41 m <sup>3</sup> /hr)		22 gpm (83.3 lpm) (5.0 m <sup>3</sup> /hr)	
	NSF/EPA 40mJ/cm <sup>2</sup> @ 95%UVT	7 gpm (26.5 lpm) (1.59 m <sup>3</sup> /hr)		12 gpm (45.4 lpm) (2.73 m <sup>3</sup> /hr)		16 gpm (60.6 lpm) (3.63 m <sup>3</sup> /hr)	
Dimensions	UV Chamber	28.4 cm x 10.16 cm (11.2" x 4.0")		42.0 cm x 10.16 cm (16.5" x 4.0")		57.2 cm x 10.16 cm (22.52" x 4.0")	
	Controller	26.67cm x 12.7 cm x 16.51cm (10.5" x 5.0" x 6.5")		26.67cm x 12.7 cm x 16.51cm (10.5" x 5.0" x 6.5")		26.67cm x 12.7 cm x 16.51cm (10.5" x 5.0" x 6.5")	
Inlet/Outlet Port Size <sup>3</sup>		Combo 3/4" FNPT / 1" MNPT <sup>2</sup>		Combo 3/4" FNPT / 1" MNPT <sup>2</sup>		Combo 3/4" FNPT / 1" MNPT <sup>2</sup>	
Shipping Weight		12 lbs (5.4 kg)		15 lbs (6.8 kg)		18 lbs (8.2 kg)	
Electrical	Voltage <sup>4</sup>	100-240 V / 50/60 Hz		100-240 V / 50/60 Hz		100-240 V / 50/60 Hz	
	Max. Current	1.5 Amp		1.5 Amp		1.5 Amp	
	Power consumption	35 W		50 W		65 W	
	Lamp Watts	24 W		38 W		52 W	
Maximum Operating Pressure		125 psi		125 psi		125 psi	
Ambient Water Temperature		2-40 °C (36-104 °F)		2-40 °C(36-104 °F)		2-40 °C (36-104 °F)	
Lamp Type		High Output		High Output		High Output	
Display		LCD Touch Screen		LCD Touch Screen		LCD Touch Screen	
Lamp Replacement Reminder		Yes		Yes		Yes	
Visual Lamp Life		Yes		Yes		Yes	
True Lamp Running time		Yes		Yes		Yes	
System Total Running Time		Yes		Yes		Yes	
UV Chamber Material		304 SS		304 SS		304 SS	
Acceptable Inlet/Outlet Piping (By others)		All standard household piping or tubing (i.e. copper, PEX, PVC, etc.)					

<sup>1</sup> Flow rates based on End of Lamp Life; 20°C.

<sup>2</sup> For units manufactured before September 09, 2024, port size = 3/4" MNPT

<sup>3</sup> Units ending in "/WR" have BSPT connections.

<sup>4</sup> Units ending in "/2" are for 230V applications.

## Section 9 Manufacturer's Warranty

---

### Our Commitment

VIQUA is committed to ensuring your experience with our products and organization exceeds your expectations. We have manufactured your UV System to the highest quality standards and value you as our customer. Should you need any support, or have questions about your system, please contact our Technical Support team at 1.800.265.7246 or [technicalsupport@viqua.com](mailto:technicalsupport@viqua.com) and we will be happy to assist you.

### How to Make a Warranty Claim

**Note:** *To maximize the performance and reliability of your VIQUA product, the system must be properly sized, installed and maintained. Guidance on the necessary water quality parameters and maintenance requirements can be found in your Owner's Manual.*

In the event that repair, or replacement of parts covered by this warranty are required, the process will be handled by your dealer. If you are unsure whether an equipment problem or failure is covered by warranty, contact our Technical Support team at 1.800.265.7246 or e-mail [technicalsupport@viqua.com](mailto:technicalsupport@viqua.com). Our fully trained technicians will help you troubleshoot the problem and identify a solution. Please have available the model number (system type), the date of purchase, the name of the dealer from whom you purchased your VIQUA product ("the source dealer"), as well as a description of the problem you are experiencing. To establish proof of purchase when making a warranty claim, you will either need your original invoice, or have previously completed your product registration online.

### Specific Warranty Coverage

Warranty coverage is specific to the VIQUA range of products. Warranty coverage is subject to the conditions and limitations outlined under "[General Conditions and Limitations](#)".

#### Ten-Year Limited Warranty for VIQUA UV Chamber

VIQUA warrants the UV Chamber on the VIQUA product to be free from defects in material and workmanship for a period of ten (10) years from the date of purchase. During this time, VIQUA will repair or replace, at its option, any defective VIQUA UV Chamber. Please return the defective part to your dealer who will process your claim.

#### Five-Year Limited Warranty for Electrical and Hardware Components

VIQUA warrants the electrical (controller) and hardware components to be free from defects in material and workmanship for a period of five (5) years from the date of purchase. During this time, VIQUA will repair or replace, at its option, any defective parts covered by the warranty. Please return the defective part to your dealer who will process your claim.

#### One-Year Limited Warranty for UV Lamp Units

VIQUA warrants UV Lamp Unit to be free from defects in material and workmanship for a period of one (1) year from the date of purchase. During this time, VIQUA will repair or replace, at its option, any defective parts covered by the warranty. Your dealer will process your claim and advise whether the defective item needs to be returned for failure analysis.

**Note:** *Use only genuine VIQUA replacement UV Lamp Units in your system. Failure to do so may seriously compromise performance and affect warranty coverage.*

### General Conditions and Limitations

None of the above warranties cover damage caused by improper use or maintenance, accidents, acts of God or minor scratches or imperfections that do not materially impair the operation of the product. The warranties also do not cover products that are not installed as outlined in the applicable Owner's Manual. Parts repaired or replaced under these warranties will be covered under warranty up to the end of the warranty period applicable to the original part. The above warranties do not include the cost of shipping and handling of returned items.

The limited warranties described above are the only warranties applicable to the VIQUA range of products. These limited warranties outline the exclusive remedy for all claims based on a failure of or defect in any of these products, whether the claim is based on contract, tort (including negligence), strict liability or otherwise. These warranties are in lieu of all other warranties whether written, oral, implied or statutory. Without limitation, no warranty of merchantability or of fitness for a particular purpose shall apply to any of these products. VIQUA does not assume any liability for personal injury or property damage caused by the use or misuse of any of the above products. VIQUA shall not in any event be liable for special, incidental, indirect or consequential damages. VIQUA's liability shall, in all instances, be limited to repair or replacement of the defective product or part and this liability will terminate upon expiration of the applicable warranty period.



425 Clair Rd. W, Guelph, Ontario, Canada N1L 1R1  
t. (+1) 519.763.1032 • ff. (+1) 800.265.7246 (US and Canada only)  
t. (+31) 73 747 0144 (Europe only) • f. (+1) 519.763.5069  
e-mail: [info@viqua.com](mailto:info@viqua.com)  
[www.viqua.com](http://www.viqua.com)

