

Owner's Manual

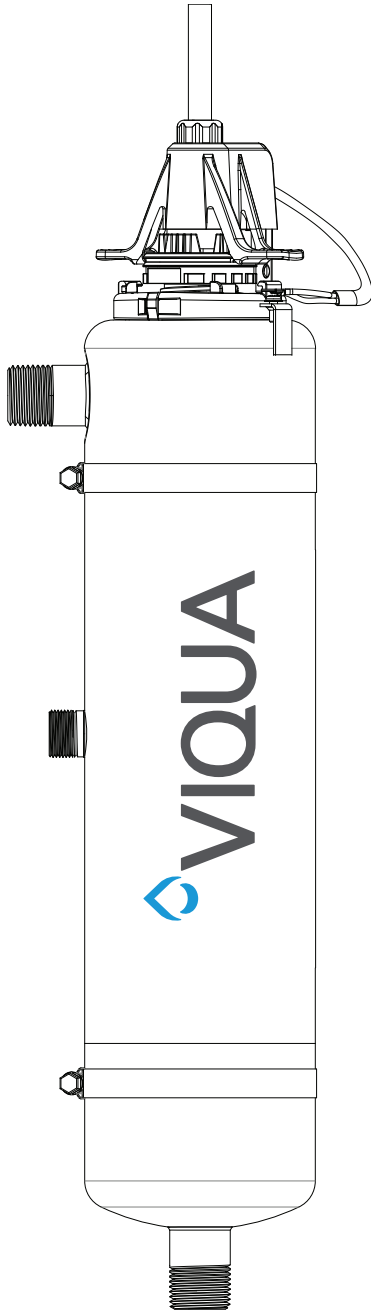

**Model:
D4**

Powered by



Congratulations

on the purchase of your ultraviolet (UV) water system! This system uses the most advanced UV technology on the market and is designed to provide you with years of trouble free operation with minimal maintenance.

To ensure ongoing optimal operation, UV lamps need to be replaced annually with VIQUA factory-supplied replacements. VIQUA lamps are the result of extensive development resulting in a highly efficient platform with extremely stable UV output over the entire 9000 hour lifetime. Its success has led to a proliferation of non-genuine copies in the market.

The UV lamp is the heart of the UV system, and there should be no compromise when it's time for a replacement.

Why should you insist on genuine factory supplied VIQUA replacement lamps?

- Use of widely available, non-genuine, replacement lamps has been shown to damage the control module of VIQUA UV equipment.
- An increasing number of calls to VIQUA Technical Support are connected with non-genuine lamps being used (unknowingly) as replacements.
- Damage arising from the use of non-genuine lamps poses a safety risk and is not covered by equipment warranty.
- Unless the UV equipment is equipped with a UV sensor (monitor), it is not possible to verify the UV (invisible) output of replacement lamps.
- Similar appearance to the original lamp and the presence of (visible) blue light does not mean equivalent performance.
- VIQUA replacement lamps undergo rigorous performance testing and strict quality control processes to ensure that the safety and performance certifications of the original equipment are not compromised.

So, you can see that it's simply not worth the risk! Insist on genuine VIQUA replacement lamps.

















Section 1 Safety Information

These are the original instructions. Please read this entire manual before operating this equipment. Pay attention to all danger, warning, and caution statements in this manual. Failure to do so could result in serious personal injury or damage to the equipment.

Make sure that the protection provided by this equipment is not impaired. Do not use or install this equipment in any manner other than that specified in the installation manual.



1.1 Potential Hazards

Read all labels and tags attached to the system. Personal injury or damage to the system could occur if not observed.

	Waste electrical and electronic equipment (WEEE). This symbol indicates that you should not discard wasted electrical or electronic equipment (WEEE) in the trash. For proper disposal, contact your local recycling/reuse or hazardous waste center.		This symbol indicates not to store any combustible or flammable material close to the system.
	This symbol indicates there is Mercury present.		This symbol indicates that the contents of the transport package are fragile and the package should be handled with care.
	This is the safety alert symbol. Obey all safety messages that follow this symbol to avoid potential injury. When on the equipment, refer to the Operational and Maintenance manual for additional safety information.		This symbol indicates safety glasses with side protection is required for protection against UV exposure.
	This symbol indicates a risk of electrical shock and/or electrocution exists.		This symbol indicates gloves must be worn.
	This symbol indicates the marked equipment may contain a component that can eject forcibly. Obey all procedures to safely depressurize.		This symbol indicates safety boots must be worn.
	This symbol indicates the system is under pressure.		This symbol indicates the operator must read all available documentation to perform required procedures.
	This symbol indicates there is a potential UV hazard. Proper protection must be worn.		This symbol indicates the plumber must use copper piping.
	This symbol indicates the marked item could be hot and should not be touched without care.		This symbol indicates that the system should only be connected to a properly grounded, grounding-type controller receptacle that is protected by a Ground Fault Circuit Interrupter (GFCI).
	This symbol indicates there is a potential for VERY hot water when flow is started.		

1.2 Safety Precautions

⚠ DANGER

 	<p>Failure to follow these instructions will result in serious injury or death.</p> <ul style="list-style-type: none"> Electric Shock: To avoid possible electric shock, special care should be taken since water is present near the electrical equipment. Unless a situation is encountered that is explicitly addressed by the provided maintenance and troubleshooting sections, do not attempt repairs yourself, refer to an authorized service facility. GROUNDING: This product must be grounded. If it should malfunction or breakdown, grounding provides a path of least resistance for electric current to reduce the risk of electrical shock. This system is equipped with a cord having an equipment-grounding conductor and a grounding plug. The plug must be plugged into an appropriate outlet that is properly installed and grounded in accordance with all local codes and ordinances. Improper connection of the equipment-grounding conductor can result in a risk of electrocution. Check with a qualified electrician or service personnel if you are in doubt as to whether the outlet is properly grounded. Do not modify the plug provided with this system – if it does not fit in the outlet, have a proper outlet installed by a qualified electrician. Do not use any type of adapter with this system. GROUND FAULT CIRCUIT INTERRUPTER PROTECTION: To comply with the National Electrical Code (NFPA 70) and to provide additional protection from the risk of electric shock, this system should only be connected to a properly grounded, grounding-type controller receptacle that is protected by a Ground Fault Circuit Interrupter (GFCI) or to a residual current device (RCD) having a rated residual operating current not exceeding 30 mA. Inspect operation of GFCI as per manufacturer’s suggested maintenance schedule. DO NOT operate the UV system if it has a damaged cord or plug, if it is malfunctioning or if it has been dropped or damaged in any manner. DO NOT use this UV system for other than intended use (potable water applications). The use of attachments not recommended or sold by the manufacturer / distributor may cause an unsafe condition. DO NOT install this UV system where it will be exposed to the weather or to temperatures below freezing. DO NOT store this UV system where it will be exposed to the weather. DO NOT store this UV system where it will be exposed to temperatures below freezing unless all water has been drained from it and the water supply has been disconnected.
--	--

Safety Information

⚠ WARNING



- During extended periods of no water flow, the water in your chamber can become very hot (Approx. 60 °C) and potentially lead to scalding. It is recommended to run your water until this hot water has been purged from your chamber. Do not allow water to contact your skin during this time. To eliminate this condition, a temperature management valve can be installed at the outlet of your UV system.



- Do not pass water through the UV system for a minimum of 5 minutes after applying power (including after power interruptions) to avoid passing under-treated water that may, in rare instances, pose health hazards.
- This system contains a UV Lamp. Do not operate the UV Lamp when it is removed from the chamber. Unintended use or damage of the system may result in the exposure of dangerous UV radiation. UV radiation may, even in little doses, cause harm to the eyes and skin.
- Changes or modifications made to this system without the consent of the manufacturer could render the system unsafe for operation and may void the manufacturer's warranty.



WARNING: This product can expose you to chemicals including phthalates, which is known to the state of California to cause cancer, and mercury, which is known to the State of California to cause birth defects or other reproductive harm. For more information go to www.P65Warnings.ca.gov.

⚠ CAUTION



Failure to follow these instructions could result in minor or moderate injury.



- Carefully examine the UV system after installation. It should not be plugged in if there is water on parts not intended to be wet such as, the controller or lamp connector.
- Due to thermal expansion concerns and potential material degradation due to UV exposure, it is recommended to use metal fittings and at least 10" of copper pipe on the outlet of your UV chamber.
- **Hg EXPOSURE:** The UV lamp contains mercury. If the lamp breaks, then avoid inhalation or ingestion of the debris and avoid exposure to eyes and skin. Never use a vacuum cleaner to clean up a broken lamp as this may scatter the spilled mercury. Obey local regulations and guidelines for the removal and disposal of mercury waste.

NOTICE



- The UV system inactivates Cryptosporidium, Giardia, Escherichia coli (E. Coli) and Fecal Coliform.
- The UV lamp inside the UV system is rated at an effective life of approximately 9000 hours. To ensure continuous protection, replace the UV lamp annually.
- The UV system is not to be used or played with by children. Persons with reduced physical, sensory or mental capabilities, or lack of experience and knowledge, are also not to handle the UV system unless they have been given supervision or instruction.
- This system is intended to be permanently connected to the water lines.
- This system is not intended to be used in or above water or outdoors or used in swimming pools when persons are in the pool.
- **EXTENSION CORDS:** If an extension cord is necessary, use only 3-wire extension cords that have 3-prong grounding-type plugs and 3-pole cord connectors that accept the plug from this system. Use only extension cords that are intended for outdoor use. Use only extension cords having an electrical rating not less than the rating of the system. A cord rated for less amperes or watts than this system rating may overheat. Exercise caution when arranging the cord so that it will not be tripped over or pulled. DO NOT use damaged extension cords. Examine extension cord before using and replace if damaged. DO NOT abuse extension cord. Keep extension cord away from heat and sharp edges. Always disconnect the extension cord from the receptacle before disconnecting this system from the extension cord. Never yank cord to pull plug from outlet. Always grasp the plug and pull to disconnect.
- If the supply cord is damaged, it must be replaced by a special cord or assembly available from the manufacturer or its service agent.
- **SYSTEM PROTECTION:** To protect your Controller, a UL1449 certified (or equivalent) transient voltage surge suppressor is strongly recommended.
- The UV lamp in this system conforms to the applicable provisions of the Code of Federal Regulations (CFR) requirements including, Title 21, Chapter 1, Subchapter J, Radiological Health.
- Read and understand the Owner's Manual before operating and performing any maintenance on this equipment.

1.3 Water Chemistry

Water quality is extremely important for the optimum performance of your UV system. The following levels are recommended for installation:

Water Quality and Minerals	Level
Iron	< 0.3 ppm (0.3 mg/L)
Hardness*	< 7 gpg (120 mg/L)
Turbidity	< 1 NTU
Manganese	< 0.05 ppm (0.05 mg/L)
Tannins	< 0.1 ppm (0.1 mg/L)
UV Transmittance, Standard Models	> 75% (call factory for recommendations on applications where UVT < 75%)

* Where total hardness is less than 7 gpg, the UV unit should operate efficiently provided the quartz sleeve is cleaned periodically. If total hardness exceeds 7 gpg, the water should be softened. If your water chemistry contains levels in excess of those mentioned above, proper pre-treatment is recommended to correct these water problems prior to the installation of

your UV system. These water quality parameters can be tested by your local dealer, or by most private analytical laboratories. *Proper pre-treatment is essential for the UV system to operate as intended.*

Section 2 General Information

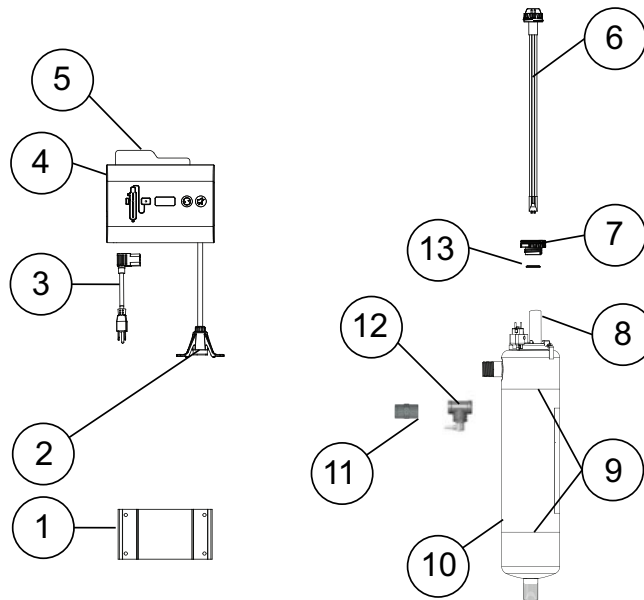

Figure 1 Model Components

Item	Description	Part Number
1	Controller mounting bracket	-
2	Lamp Connector	-
3	Power cord	602636 (120V)
		602637 (230V)
4	Controller (includes controller mounting bracket, reference card and lamp connector)	650733R-002
5	Reference card	603069
6	Lamp (includes O-ring)	602805
7	Sleeve bolt	602665
8	Sleeve (includes O-ring)	602732
9	Chamber clamp(s)	-
10	UV Chamber	650712-013
11	Flow Restrictor (optional)	440267-R
12	CoolTouch valve (optional)	650537
13	O-ring	002045

To find out what model you have, look at the label on the side of the controller as depicted below:

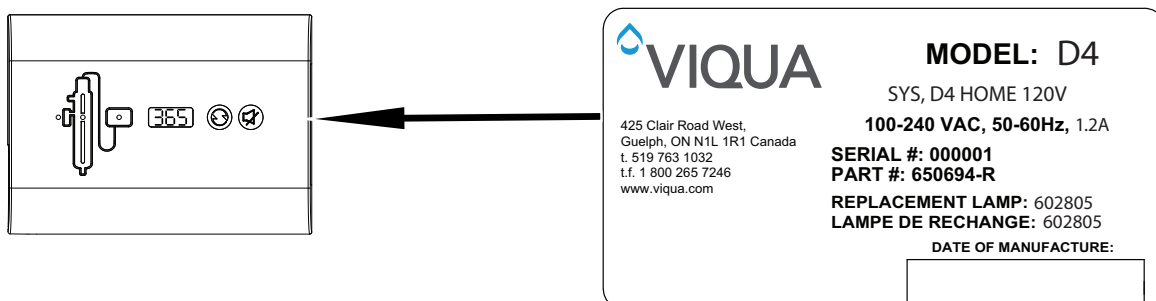

Figure 2 Model D- Controller Components

General Information

Operating Parameters	D4
No-tools maintenance	Yes
Special lamp plug	Yes
Lamp operation indicator	Yes
Controller operation indicator	Yes
Reference card	Yes
Lamp timer display	Yes
Lamp timer reset button	Yes
Mute button	Yes

2.1 Dimensions and Layout

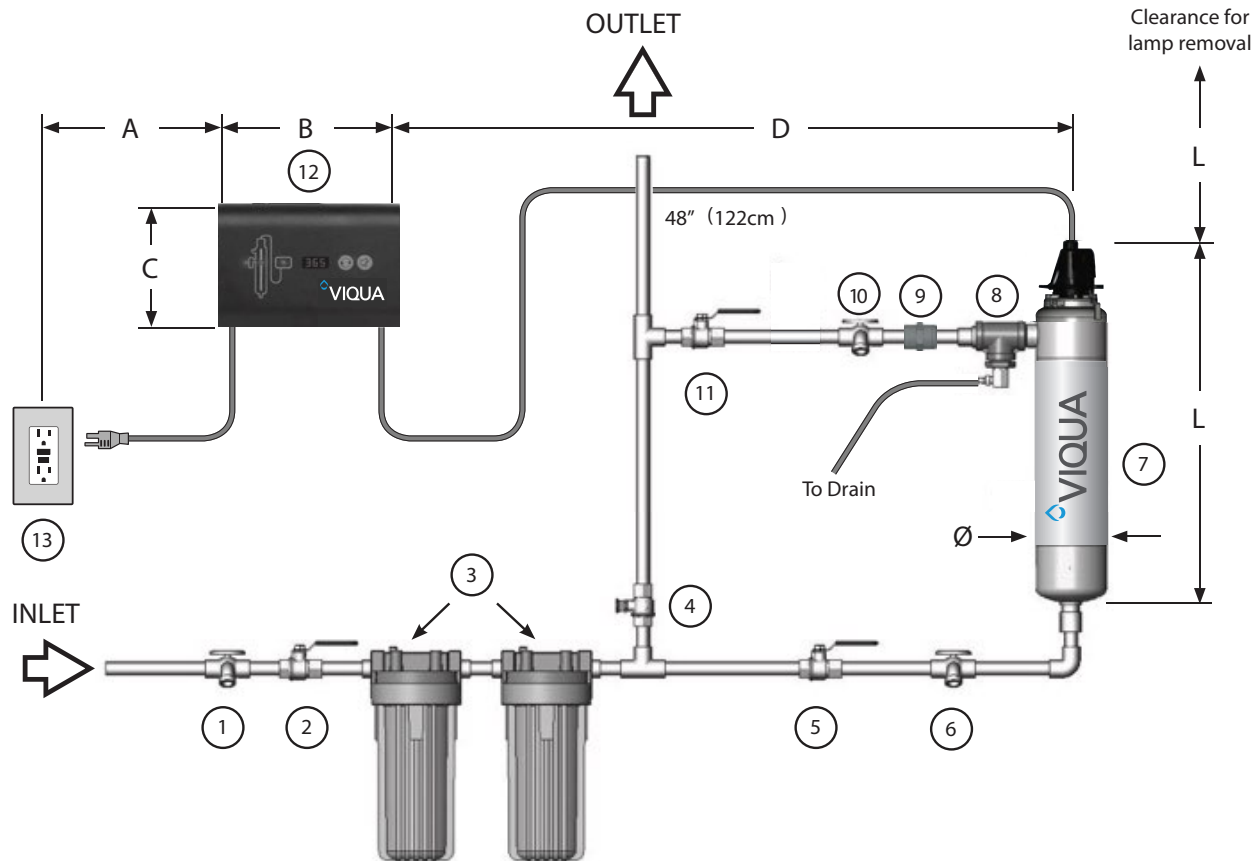

Figure 3 System - Dimension and Layouts

Item	Description	Function
1	Sample valve	Allows for sampling of raw water.
2	Shut-off valve	Required to allow maintenance of pre-treatment equipment.
3	Pre-treatment	Refer to Section 1.3 . Note: A 5 micron (nominal) sediment filter must be installed before the UV system and after any water softening equipment.
4	Bypass shut-off valve	Bypass line and valve are optional. Intended to provide emergency water supply in the event that the UV system is unavailable.
5	Shut-off valve	Required to allow maintenance of UV system.
6	Sample valve	Allows for sampling of water entering UV chamber.
7	UV chamber	Provides UV treatment of the water.
8	CoolTouch™ valve	Drains water from the chamber that's been warmed by the lamp during periods of no flow.

Item	Description	Function
9	Flow Restrictor	Restricts water from flowing over the maximum NSF certified flow rate ensuring an adequate UV dose is maintained.
10	Sample valve	Allows for sampling of water; necessary in order to confirm proper operation of UV system.
11	Shut-off valve	Required to allow maintenance of UV system.
12	Controller	Powers and controls the UV lamp and other devices. Provides human interface, displaying information and allowing control inputs (such as muting the audible alarm).
13	Power source	Provides power to the controller. For safety reasons the outlet must be protected by a Ground Fault Circuit Interrupter (GFCI). Note: To protect the controller, a UL1449 certified (or equivalent) transient voltage surge suppressor is required.

Model	L	Ø	A (maximum)	B	C	D (maximum)
D4	20.5" (52cm)	4" (10cm)	72" (183cm)	8.5" (22cm)	6" (15cm)	54" (137cm)

Section 3 Installation

⚠ CAUTION



Electronic controller must be connected to a Ground Fault Protected Circuit (GFCI) receptacle. Ensure green ground wire ring terminal is securely fastened to ground stud on UV chamber.

Due to thermal expansion concerns and potential material degradation due to UV exposure, it is recommended to use metal fittings and at least 10" of copper pipe on the outlet of your UV chamber.

3.1 Installing UV System

The UV system is designed to be mounted either horizontally or vertically at the point-of-use or point-of-entry depending on the specific flow rate of the unit.

If installing the chamber in horizontal position the outlet port must be pointing upwards to ensure all air is fully purged from the chamber.

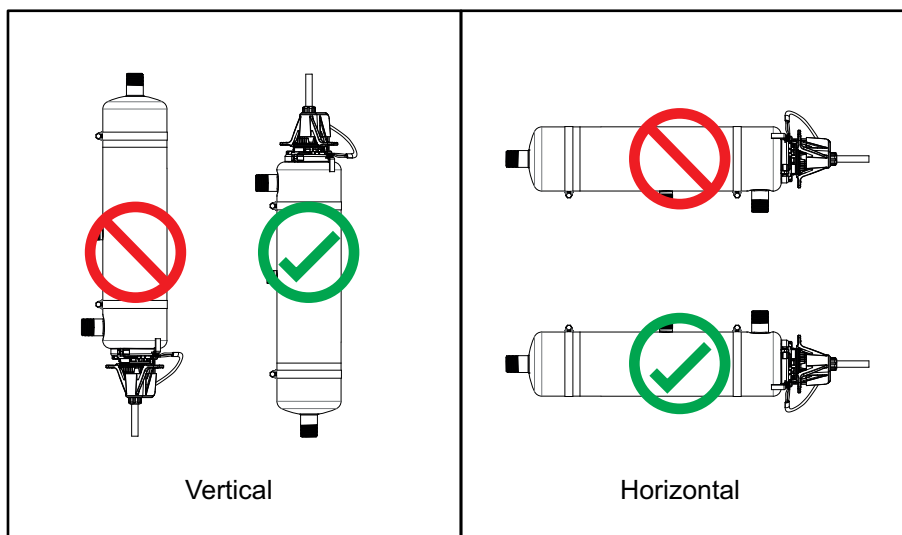

Figure 4 UV System Installation - Vertical and Horizontal

Note: The ideal installation is vertical with the lamp connector on top. This is to prevent water damage from occurring on the lamp pins and lamp connector.

Installation

Prerequisites:

- Determine appropriate indoor location of the controller and chamber. Refer to [Figure 3](#).
- Ensure adequate clearance above chamber to allow for removal of the lamp and sleeve.
- Make sure to turn off the main water supply.
- Mount the system to the wall with appropriate lag bolts through the two mounting holes located on the metal bracket. The supplied lag bolts are suitable for attachment to wood. (Attachments to other materials will require purchasing of alternative hardware).
- Make all necessary plumbing connections. Refer to [Figure 3](#).

Procedure:

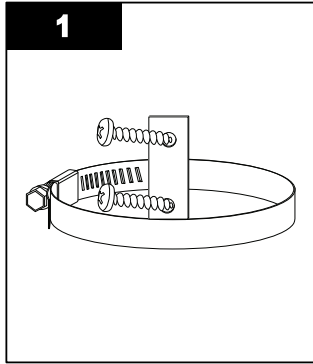

- Screw chamber clamp(s) to the wall (#10 screws recommended.)

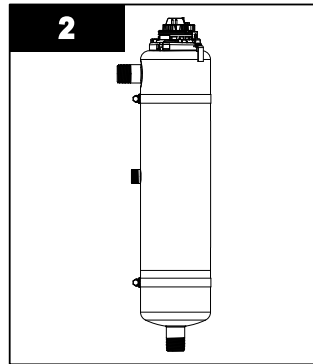

- Insert chamber and tighten clamp(s).
- Make all necessary plumbing connections. Refer to [Section 2.1](#).

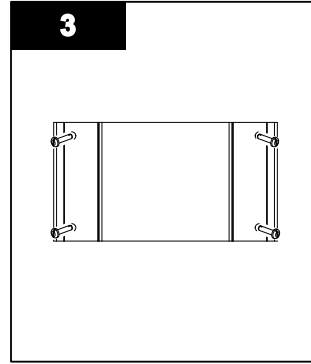

- Mount controller mounting bracket to wall using four #8 screws (not provided).

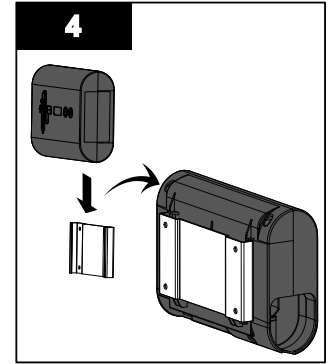

- Slide controller onto mounting bracket.

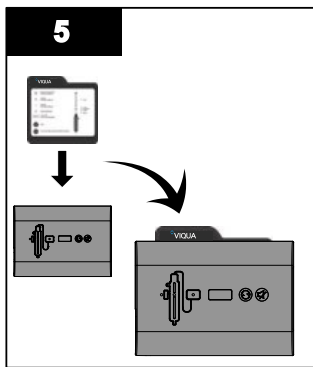

- Insert the reference card between controller and mounting bracket.

Note: Outlet must be protected by a Ground Fault Circuit Interrupter (GFCI).

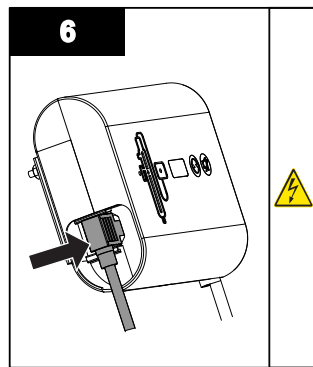

- Connect power cord to controller.
- DO NOT connect the power cord to the GFCI outlet at this time.

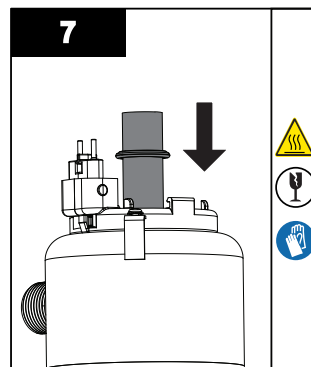

- Place O-ring on the sleeve as shown. Insert the sleeve into the chamber as shown in step 8.

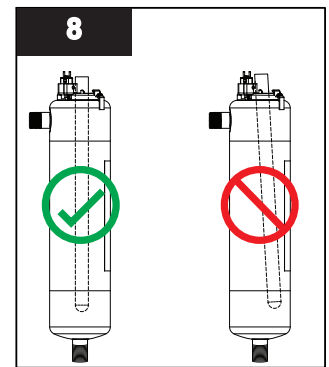

- Ensure quartz sleeve is properly centered in the chamber.

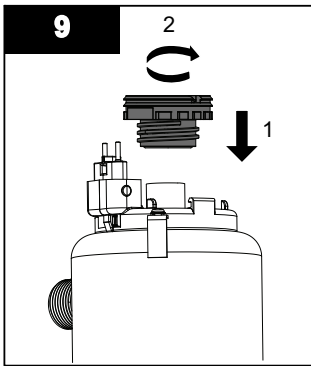

- Place sleeve bolt onto the quartz sleeve, carefully push down and hand tighten onto chamber.

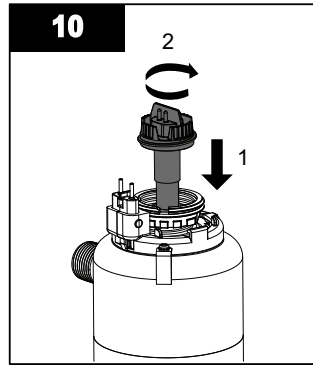

- Insert lamp into the quartz sleeve and thread into sleeve bolt until hard stop.

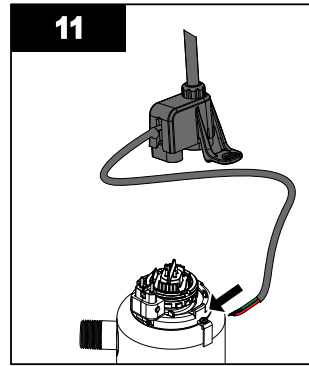

- Connect the green ground wire and red strain relief wire to the chamber using the grounding screw.

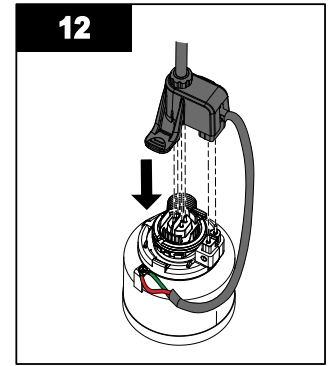

- Align connection pins with the lamp connector by rotating the ring clamp.
- Push the lamp connector down onto the lamp pins and the ring clamp pins until an audible click is heard.

Note: Ensure the connector is engaged on both sides.

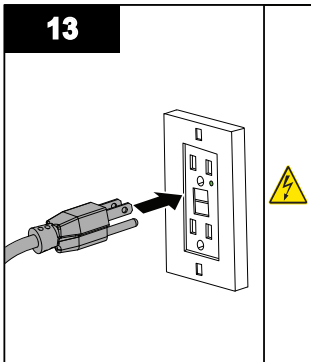

- Connect power.
- Open all faucets and turn on water supply. Inspect for any leaks.

Note: Outlet must be protected by a Ground Fault Circuit Interrupter (GFCI).

3.2 Disinfection Procedure

It is imperative that the entire distribution system located after the UV be chemically cleaned to ensure that the plumbing system is free from any contaminants. The cleaning process must be performed immediately after the UV unit is installed and repeated thereafter whenever the UV is shut down for service, without power, or inoperative for any reason. The procedure for cleaning the plumbing system is readily accomplished as follows:

Installation

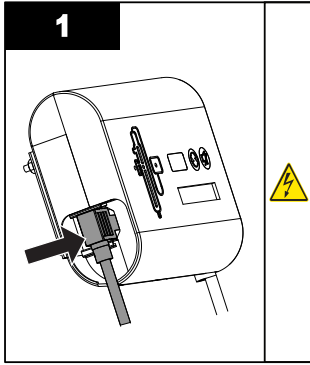

- Ensure only the controller plug is plugged in for entire cleaning process.

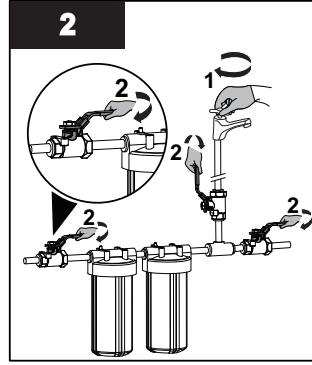

- Shut off the water supply.
- Close each faucet.

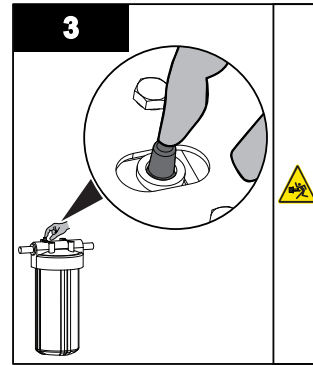

- Press the pressure button to release the pressure from the cartridges.

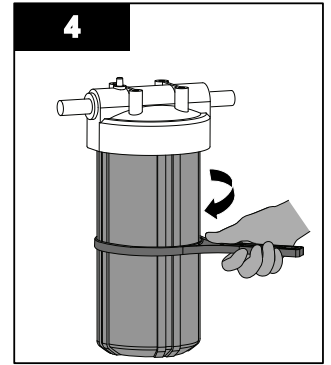

- Remove sump housing(s) using sump wrench.

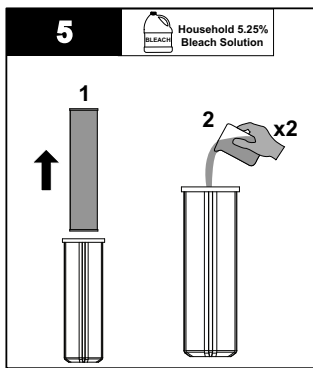

- Remove cartridge(s) and pour 2 cups of household bleach solution into the sump housing(s).
- Note:** DO NOT use Hydrogen Peroxide.

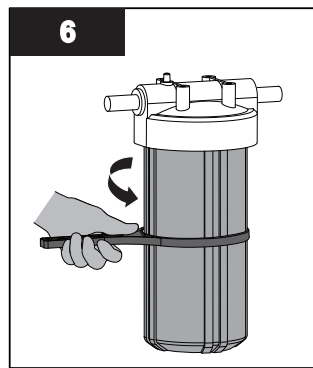

- Reinstall sump only to filter head.

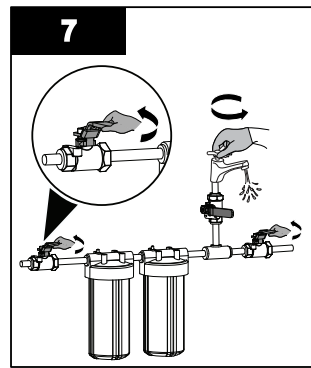

- Turn on water supply.
- Allow water to fill the chamber.

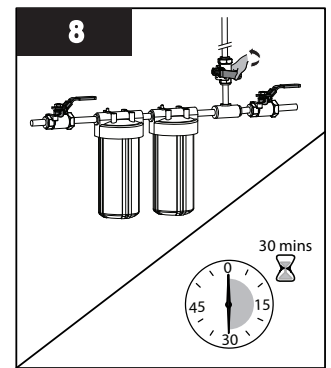

- Turn on the cold water supply followed by hot water (if available) until you smell the bleach.
- Close all faucets and allow bleach to settle in the water lines for 30 minutes.

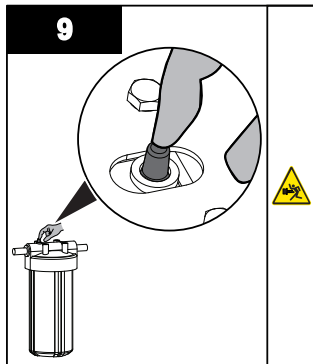

- Press the pressure button to release the pressure.

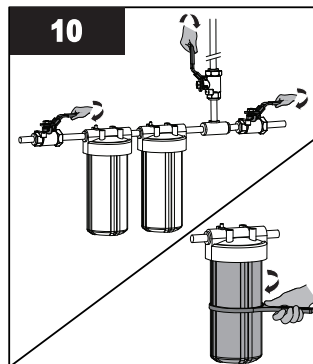

- With all faucets closed, remove sump housing(s) using sump wrench.

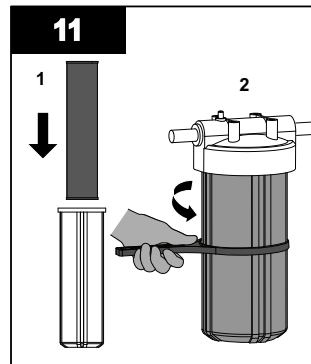

- Reinstall the cartridge(s) into sump housing(s) and connect to the unit.
- Flush all water outlets until bleach can no longer be smelled (at least 5 minutes).

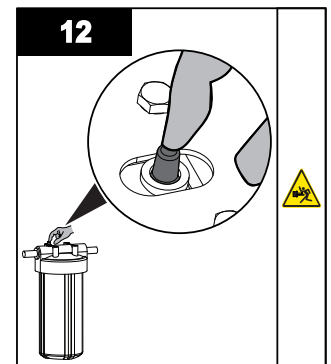

- Press the pressure button to purge air and to complete the cleaning procedure.

Section 4 Operation

4.1 Control Panel

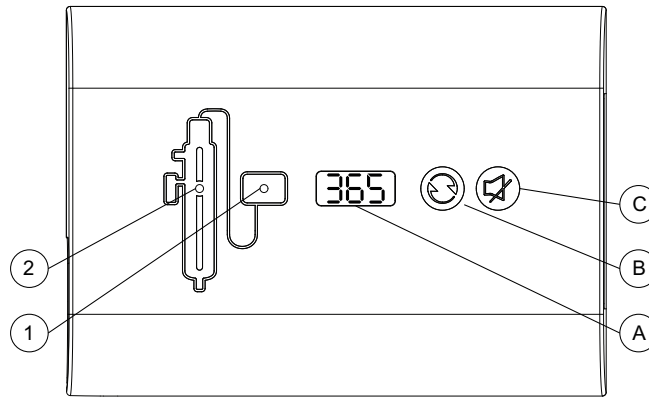

Figure 5 Control Panel

Buttons and Display		
Feature	Description	Function
A	Lamp timer display	Counts down from 365 days to show time for annual lamp replacement.
B	Lamp timer reset	After installing a new lamp, press and hold for five seconds to reset Lamp timer to 365.
C	Mute	<ul style="list-style-type: none"> Press to silence audible alarm. When the alarm is due to the lamp's age, the mute button will silence the audible alarm for 7 days; this may be repeated up to a maximum of 4 times. After that, the button will silence for only 24 hours. When the alarm is due to any other issue, the mute button will silence the audible alarm for 24 hours.

Indicator Lights				
Normal Operating Conditions	LED 1 (UV Controller Status)	LED 2 (UV Lamp Status)	Audio Indicator Status	Notes
Lamp warm-up	Green	Flashing Green	Off	It may take up to 2.5 minutes for the lamp to warm up and the LED 2 to be solid green.
Normal Operation	Green	Green	Off	

Alarm/Fault Condition	LED 1 (UV Controller Status)	LED 2 (UV Lamp Status)	Audio Indicator Status	Notes
UV Lamp Ignition/Run Fault	Red	Flashing Red	Beeping	<ol style="list-style-type: none"> Unplug UV system from main power supply. Check for secure lamp connection. Restore power to UV system. If failure message repeats, replace UV lamp. Audible alarm may be silenced for 24 Hours.
UV Lamp Near End of Life Warning	Green	Yellow	Off	Warning: Lamp will require replacement shortly.
UV Lamp At End of Life Fault	Green	Flashing Red	Chirp	<ol style="list-style-type: none"> Follow instructions in manual to replace lamp. Warning Chirp may be silenced for 7 Days.
UV Lamp EOL Exceeded Fault	Green	Flashing Red	Chirp	<ol style="list-style-type: none"> Follow instructions in manual to replace lamp. Warning Chirp may be silenced for 24 Hours.
AC Voltage out of Range	Flashing Red	Flashing Red	Beeping	When the AC voltage is back in range (>93V or <265V) the alarm cancels and normal operation is resumed. Audible alarm may be silenced temporarily.
UV Controller Fault	Flashing Red	Red	Beeping	<ol style="list-style-type: none"> Unplug UV system from main power supply. Allow 30 seconds for unit to fully power down. Restore power to UV system. If failure message repeats, replace controller. Audible alarm may be silenced for 24 Hours.

Section 5 Maintenance

⚠ WARNING



- Always disconnect power before performing any work on the UV system.
- Always shut-off water flow and release water pressure before servicing.
- Regularly inspect your UV system to ensure that the power indicators are on and no alarms are present.
- Replace the UV lamp annually (or biennially if seasonal home use) to ensure maximum performance.
- Always drain the chamber when closing a seasonal home or leaving the unit in an area subject to freezing temperatures.

5.1 Replacing UV Lamp

NOTICE

Do not use water during replacement of UV lamp.

Lamp replacement is a quick and simple procedure requiring no special tools. The UV lamp must be replaced after 9000 hours of continuous operation (approximately one year) in order to ensure adequate performance.

Procedure:

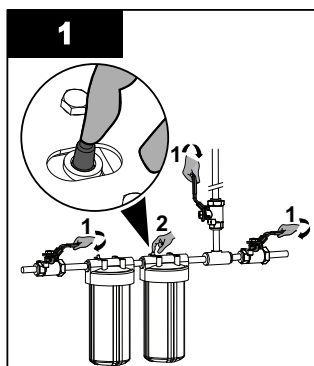

- Close all faucets and water supply.
- Press the pressure release button to relieve the pressure from the cartridges.

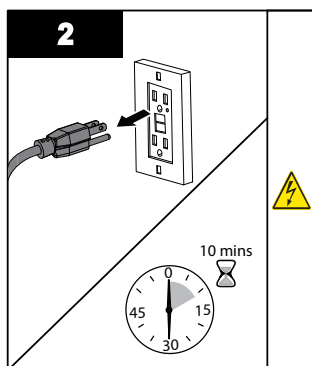

- Disconnect main power source and allow the unit to cool for 10 minutes.

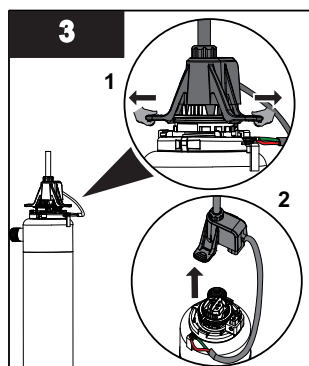

- Remove the lamp connector by pulling the tabs out and then upwards.

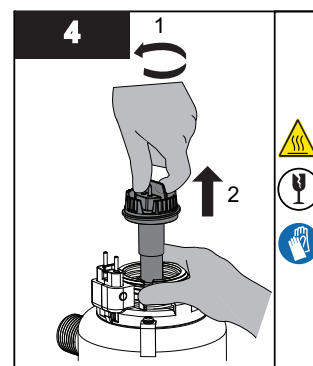

- Hold sleeve bolt with one hand and turn lamp counter-clockwise and pull the lamp outside the chamber in upward direction.

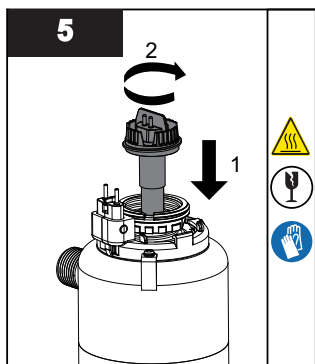

- Insert new lamp into the quartz sleeve and thread into sleeve bolt until hard stop.

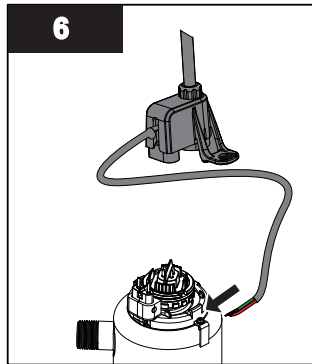

- Connect the green ground wire and red strain relief wire to the chamber using the grounding screw.

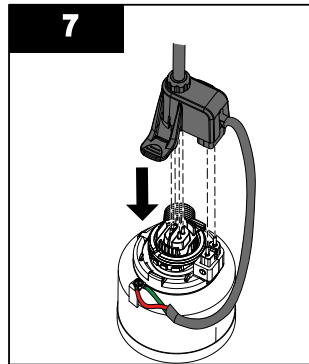

- Align connection pins with the lamp connector by rotating the ring clamp.
- Push the lamp connector down onto the lamp pins and the ring clamp pins until an audible click is heard.

Note: Ensure the connector is engaged on both sides.

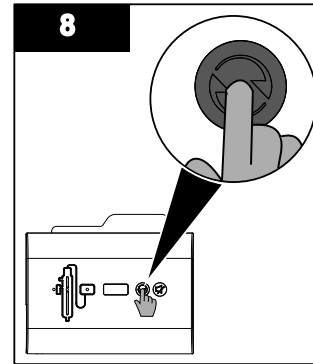

- Restore power.
- If new lamp was inserted, press and hold lamp timer reset button for 5 seconds. Display should read [365].
- Open all faucets and water inlets. Inspect for any leaks.

5.2 Cleaning and Replacing Quartz Sleeve

Note: Minerals in the water slowly form a coating on the quartz sleeve. This coating must be removed because it reduces the amount of UV light reaching the water, thereby reducing performance. If the sleeve can not be cleaned, it must be replaced.

Prerequisites:

- Shut off water supply and drain all lines.
- Depressurize the unit. Place a small pail under the unit to catch any spills.
- Remove the UV lamp. Refer to [Section 5.1](#).

Procedure:

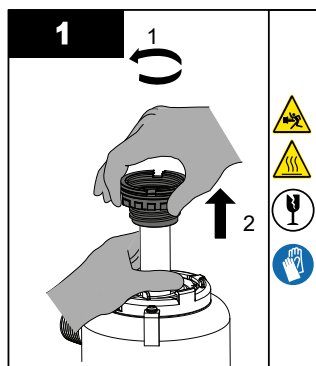

- Unscrew the sleeve bolt and carefully remove it from the top of the chamber.

Note: Sleeve may be attached to sleeve bolt. Hold sleeve with other hand while removing sleeve bolt.

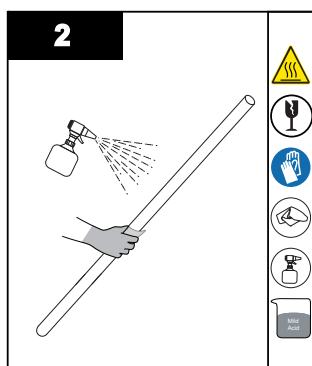

- Clean the quartz sleeve with a cloth soaked in CLR, vinegar or some other mild acid and then rinse with water.

Note: If sleeve cannot be cleaned completely or it is scratched or cracked, then replace the sleeve.

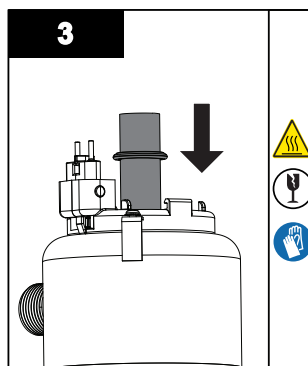

- Place O-ring on the sleeve as shown. Insert the sleeve into the chamber as shown in step 4.

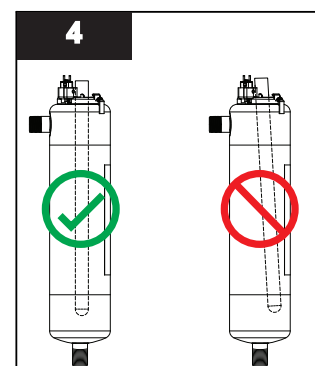

- Ensure quartz sleeve is properly centered in the chamber.

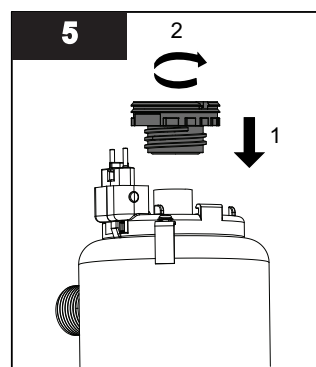

- Place sleeve bolt onto the quartz sleeve, carefully push down and hand tighten onto chamber.
- When service is complete, assemble the prerequisites in the reverse order of disassembly.

Notes: 1) After replacing the UV lamp or quartz sleeve perform the cleaning procedure, refer to [Section 3.2](#).

2) If the system is put on a temporary by-pass or if it becomes contaminated after the UV system, it is necessary to complete the cleaning procedure, refer to [Section 3.2](#).

Section 6 Troubleshooting

Symptom	Possible Cause	Possible Solution
No power	GFCI and/or breaker tripped	Reset GFCI and/or breaker
	Transient voltage surge suppressor (TVSS) damaged	Replace TVSS
	Controller damaged	Replace controller and use a TVSS
GFCI or breaker repeatedly trips	Connection between lamp and lamp plug is wet	Clean and dry lamp pins and lamp plug, check unit for leaks or condensation
	Short-circuit in the electrical assembly	Replace controller
Leak at inlet or outlet	Threaded pipe fittings are leaking	Clean threads, reseal with Teflon tape and retighten
Leak detected from area of UV chamber	Condensation of moist air on cold chamber (slow accumulation)	Control humidity or relocate unit.
	O-ring damaged, deteriorated or incorrectly installed	Inspect and replace if deteriorated.
	Lamp/sleeve assembly not properly installed (too tight or not tight enough)	Tighten assembly hand-tight.
Alarm	Refer to Section 4.1 .	Refer to Section 4.1 .
System is operating but water tests reveal bacterial contamination	Equipment downstream of UV system is acting as a breeding ground for pathogens	Ensure UV is the last piece of equipment
	Pathogens are residing in the distribution lines post-UV	Ensure all distribution lines have been cleaned with chlorine. Refer to Section 3.2 .
	Recontamination from pipe dead-ends	Remove any pipe dead-ends and flush with chlorine. Refer to Section 3.2 .
Lamp timer does not read anything	Unit is unplugged.	Plug unit into AC power outlet
	No power at AC power outlet	Replace fuse or reset breaker
	Power cord is damaged	Replace power cord
	Power surge caused damage to electrical assembly	Replace controller and use a surge protector (TVSS)

Section 7 Specifications

Operating Parameters	D4
Maximum operating pressure	125 PSI (862 kPa)
Minimum operating pressure	4 PSI (27.5 kPa)
Maximum ambient air temperature	104 °F (40 °C)
Minimum ambient air temperature	32 °F (0 °C)
Maximum humidity	100%
Maximum hardness	120 ppm (7 grains per gallon)
Maximum iron	0.3 ppm
UVT	Minimum 75%
Installation	Vertical or horizontal
Flow Restrictor*	Yes
Rated service life of lamp	1 year
UV System Certification	
* - Optional, sold separately for D4 model.	

	Model	D4
Flow Rate ¹	Maximum rated flow at dose of 16 mJ/cm ² @ 95% UVT	23 gpm (87 lpm) (5.22 m ³ /hr)
	Maximum rated flow at dose of 30 mJ/cm ² @ 95% UVT	12 gpm (45 lpm) (2.73 m ³ /hr)
	Maximum rated flow at dose of 40 mJ/cm ² @ 95% UVT	9 gpm (34 lpm) (2.04 m ³ /hr)
Electrical	Voltage	100-240V AC
	Frequency	50/60 Hz
	Max. current	0.5 Amp
	Max. power consumption	50 Watts
	Lamp power	40 Watts
Other	UV Chamber Material	304 SST
	Inlet/Outlet	3/4" NPT

¹ Flow rates based on End of Lamp Life; 20°C.

Section 8 Manufacturer's Warranty

Our Commitment

VIQUA is committed to ensuring your experience with our products and organization exceeds your expectations. We have manufactured your UV system to the highest quality standards and value you as our customer. Should you need any support, or have questions about your system, please contact our Technical Support team at 1.800.265.7246 or technicalsupport@viqua.com and we will be happy to assist you.

How to Make a Warranty Claim

Note: *To maximise the performance and reliability of your VIQUA product, the system must be properly sized, installed and maintained. Guidance on the necessary water quality parameters and maintenance requirements can be found in your Owner's Manual.*

In the event that repair or replacement of parts covered by this warranty are required, the process will be handled by your dealer. If you are unsure whether an equipment problem or failure is covered by warranty, contact our Technical Support team at 1.800.265.7246 or e-mail technicalsupport@viqua.com. Our fully trained technicians will help you troubleshoot the problem and identify a solution. Please have available the model number (system type), the date of purchase, the name of the dealer from whom you purchased your VIQUA product ("the source dealer"), as well as a description of the problem you are experiencing. To establish proof of purchase when making a warranty claim, you will either need your original invoice, or have previously completed and returned your product registration card via mail or online.

Specific Warranty Coverage

Warranty coverage is specific to the VIQUA range of products. Warranty coverage is subject to the conditions and limitations outlined under "[General Conditions and Limitations](#)".

Ten-Year Limited Warranty for VIQUA UV Chamber

VIQUA warrants the UV chamber on the VIQUA product to be free from defects in material and workmanship for a period of ten (10) years from the date of purchase. During this time, VIQUA will repair or replace, at its option, any defective VIQUA UV chamber. Please return the defective part to your dealer who will process your claim.

Three-Year Limited Warranty for Electrical and Hardware Components

VIQUA warrants the electrical (controller) and hardware components to be free from defects in material and workmanship for a period of three (3) years from the date of purchase. During this time, VIQUA will repair or replace, at its option, any defective parts covered by the warranty. Please return the defective part to your dealer who will process your claim.

One-Year Limited Warranty for Lamps, Sleeves, and UV Sensors

VIQUA warrants lamps, sleeves, and UV sensors to be free from defects in material and workmanship for a period of one (1) year from the date of purchase. During this time, VIQUA will repair or replace, at its option, any defective parts covered by the warranty. Your dealer will process your claim and advise whether the defective item needs to be returned for failure analysis.

Note: *Use only genuine VIQUA replacement lamps and sleeves in your system. Failure to do so may seriously compromise performance and affect warranty coverage.*

General Conditions and Limitations

None of the above warranties cover damage caused by improper use or maintenance, accidents, acts of God or minor scratches or imperfections that do not materially impair the operation of the product. The warranties also do not cover products that are not installed as outlined in the applicable Owner's Manual.

Parts repaired or replaced under these warranties will be covered under warranty up to the end of the warranty period applicable to the original part.

The above warranties do not include the cost of shipping and handling of returned items

The limited warranties described above are the only warranties applicable to the VIQUA range of products. These limited warranties outline the exclusive remedy for all claims based on a failure of or defect in any of these products, whether the claim is based on contract, tort (including negligence), strict liability or otherwise. These warranties are in lieu of all other warranties whether written, oral, implied or statutory. Without limitation, no warranty of merchantability or of fitness for a particular purpose shall apply to any of these products.

VIQUA does not assume any liability for personal injury or property damage caused by the use or misuse of any of the above products. VIQUA shall not in any event be liable for special, incidental, indirect or consequential damages. VIQUA's liability shall, in all instances, be limited to repair or replacement of the defective product or part and this liability will terminate upon expiration of the applicable warranty period.



425 Clair Rd. W, Guelph, Ontario, Canada N1L 1R1
t. (+1) 519.763.1032 • ff. (+1) 800.265.7246 (US and Canada only)
t. (+31) 73 747 0144 (Europe only) • f. (+1) 519.763.5069
e-mail: info@viqua.com
www.viqua.com

